

# **HP XP7 Encryption Ready Disk Adapter (eDKA) Level1**

**FIPS 140-2**

## **Non-Proprietary Cryptographic Module Security Policy**

**Version: 2.0**

**Date: January 29, 2016**

## Table of Contents

<b>1</b>	<b>Introduction .....</b>	<b>4</b>
1.1	Hardware and Physical Cryptographic Boundary.....	5
1.2	Mode of Operation.....	6
<b>2</b>	<b>Cryptographic Functionality .....</b>	<b>7</b>
2.1	Critical Security Parameters .....	7
<b>3</b>	<b>Roles, Authentication and Services .....</b>	<b>9</b>
3.1	Assumption of Roles.....	9
3.2	Authentication Methods .....	9
3.3	Services.....	10
<b>4</b>	<b>Self-tests .....</b>	<b>13</b>
<b>5</b>	<b>Physical Security Policy .....</b>	<b>14</b>
<b>6</b>	<b>Operational Environment .....</b>	<b>14</b>
<b>7</b>	<b>Mitigation of Other Attacks Policy.....</b>	<b>14</b>
<b>8</b>	<b>Security Rules and Guidance .....</b>	<b>15</b>
8.1	Crypto Officer Guidance.....	15
8.2	User Guidance .....	16
<b>9</b>	<b>Design Assurance Policy.....</b>	<b>17</b>
9.1	Configuration Management Overview.....	17
9.2	Installation, Initialization, and start-up Overview.....	17
9.3	Secure Delivery and Operation Overview .....	17
<b>10</b>	<b>References and Definitions .....</b>	<b>18</b>

## List of Tables

Table 1 – Cryptographic Module Configurations .....	4
Table 2 – Security Level of Security Requirements .....	4
Table 3 – Ports and Interfaces .....	6
Table 4 – Approved and CAVP Validated Cryptographic Functions.....	7
Table 5 – Non-Approved but Allowed Cryptographic Functions .....	7
Table 6 – Critical Security Parameters (CSPs) .....	7
Table 7 – Roles Description.....	9
Table 8 – Authentication Description .....	10
Table 9 – Authenticated Services.....	10
Table 10 – Unauthenticated Services .....	10
Table 11 – CSP Access Rights within Services .....	12
Table 12 – Power Up Self-tests .....	13
Table 13 – Conditional Self-tests .....	14
Table 14 – References.....	18
Table 15 – Acronyms and Definitions .....	18

## List of Figures

Figure 1 – Module Block Diagram.....	5
--------------------------------------	---

## 1 Introduction

This non-proprietary document defines the Security Policy for the HP XP7 Encryption Ready Disk Adapter (eDKA) Level1, hereafter denoted the Module. The Module is 6 Gb/s SAS I/O Module with Encryption. The Module provides high speed data at rest encryption for HP storage. The Module meets FIPS 140-2 overall Level 1 requirements.

**Table 1 – Cryptographic Module Configurations**

	Module	HW P/N and Version	FW Version
1	HP XP7 Encryption Ready Disk Adapter (eDKA) Level1	R800L1	02.09.28.00 02.09.32.00 02.09.37.00

The Module is intended for use by US Federal agencies and other markets that require FIPS 140-2 validated SAS I/O module used for HP storage system with data at rest encryption feature. The Module is a hardware cryptographic module with multi-chip embedded embodiment.

The FIPS 140-2 security levels for the Module are as follows:

**Table 2 – Security Level of Security Requirements**

Security Requirement	Security Level
Cryptographic Module Specification	1
Cryptographic Module Ports and Interfaces	1
Roles, Services, and Authentication	2
Finite State Model	1
Physical Security	1
Operational Environment	N/A
Cryptographic Key Management	1
EMI/EMC	1
Self-Tests	1
Design Assurance	2
Mitigation of Other Attacks	N/A
Overall	1

## 1.1 Hardware and Physical Cryptographic Boundary

The physical form of the Module is depicted in Figure 1. Red dotted line shows the cryptographic boundary. Major components of the Module are module board, micro processor, non-volatile memories and interfaces. The Module relies on HP storage as input/output devices.

The firmware running on the micro processor is responsible for processing IOs to HDDs as well as encrypting/decrypting IOs where applicable. AES and SHA hardware accelerators are integrated into the micro processor. Firmware images are stored in the flash memory. They are loaded to the micro processor when the Module power up. All functions and system initialization are performed by the micro processor, which is contained within the cryptographic boundary of the module. CSPs are stored in flash memory or SEEPROM.

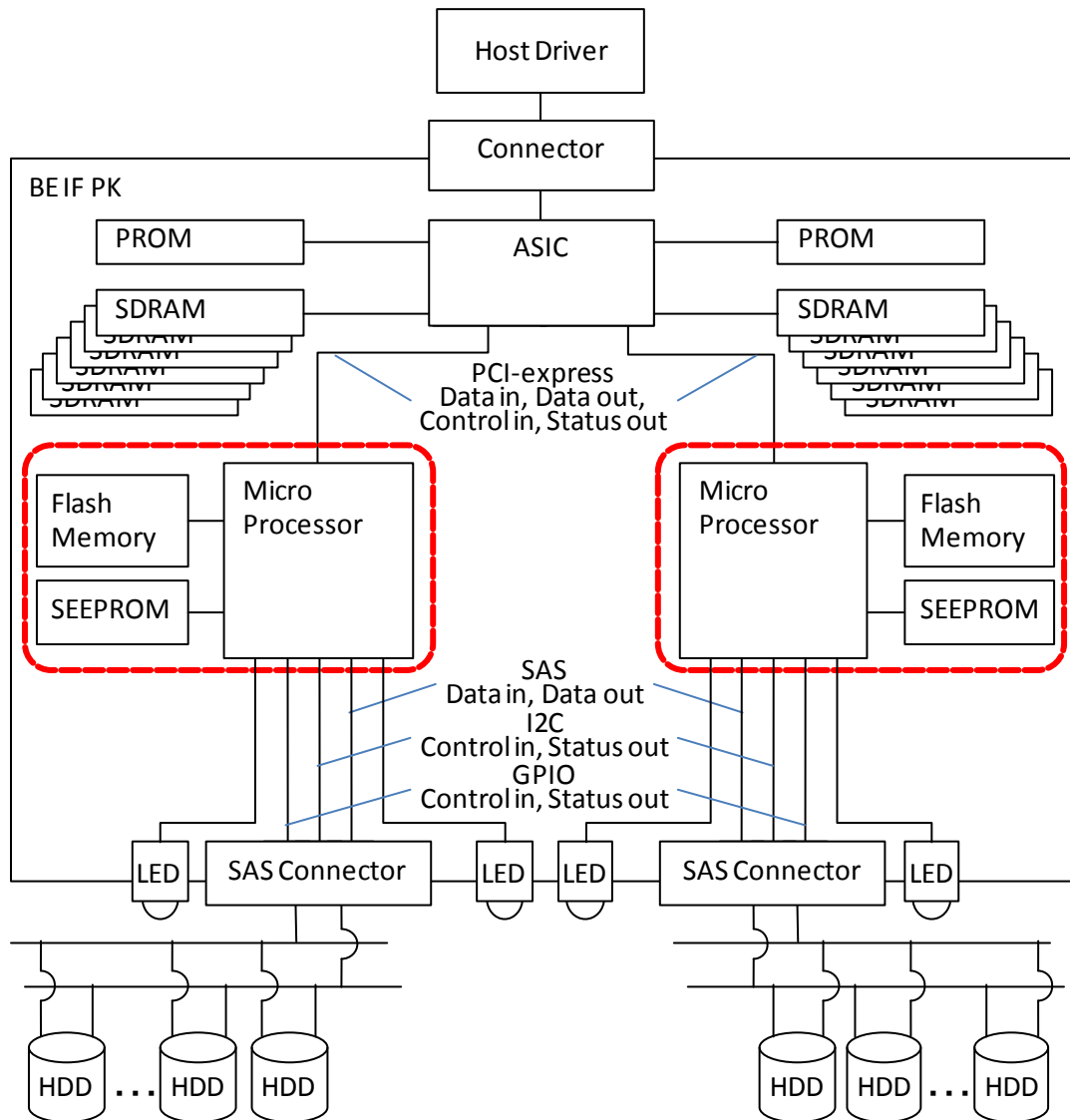

Figure 1 – Module Block Diagram

**Table 3 – Ports and Interfaces**

Port	Description	Logical Interface Type
PCI-express	plaintext input/output, module control data input, module status data output	- Control in / Status out - Data in / Data out
GPIO	module control data input, module status data output	- Control in / Status out
I2C	module control data input, module status data output	- Control in / Status out
Power	12V power input	- Power
SAS	cipher text input/output	- Data in / Data out
LED	module status output	- Status out

## **1.2 Mode of Operation**

The Module encrypts and decrypts data using only a FIPS-approved mode of operation. It does not have any functional non-approved modes.

## 2 Cryptographic Functionality

The Module implements the FIPS Approved and Non-Approved but Allowed cryptographic functions listed in the tables below.

**Table 4 – Approved and CAVP Validated Cryptographic Functions**

Algorithm	Description	Cert #
AES	[ <a href="#">SP 800-38A</a> ] Functions: Encryption, Decryption Modes: ECB Key sizes: 256 bits	3341
XTS-AES mode	[ <a href="#">SP 800-38E</a> ] Functions: Encryption, Decryption Key sizes: 256 bits	3341
SHA	[ <a href="#">FIPS 180-4</a> ] Functions: Calculation of HMAC SHA sizes: SHA-1, SHA-224, SHA-256, SHA-384, SHA-512	2775
HMAC	[ <a href="#">FIPS 198-1</a> ] Functions: MAC generation SHA sizes: SHA-1, SHA-224, SHA-256, SHA-384, SHA-512	2131

**Table 5 – Non-Approved but Allowed Cryptographic Functions**

Algorithm	Description
AES Key Wrap/Unwrap	[ <a href="#">IG D.9</a> ] and [ <a href="#">AES Key Wrap Specification, Nov 2001</a> ] AES (Cert. #3341, key wrapping; key establishment methodology provides 256 bits of encryption strength)

### 2.1 Critical Security Parameters

All CSPs used by the Module are described in this section. All usage of these CSPs by the Module (including all CSP lifecycle states) is described in the services detailed in Section 3.

**Table 6 – Critical Security Parameters (CSPs)**

CSP	Description / Usage
KEKini	256-bit factory-set key used to unwrap KEK. KEK wrapped with KEKini is entered to the module. KEK management service zeroizes KEKini by overwriting with 0xFF.
KEK	256-bit key used to unwrap DEKs and operator keys. DEKs and operator keys wrapped with KEK are entered to the module. KEK management service zeroizes KEK by overwriting with 0xFF.

CSP	Description / Usage
DEK	Two 256-bit keys used for XTS-AES encryption/decryption. DEK service zeroizes DEK by overwriting with 0x00.
Operator Key	256-bit key used to unwrap operator certificate. Operator Management service zeroizes operator key by overwriting with 0xFF.
HMAC Key	256-bit key used for authenticating firmware loaded from host. HMAC key management service zeroizes HMAC key by overwriting with 0x00.



### 3 Roles, Authentication and Services

#### 3.1 Assumption of Roles

The Module supports two distinct operator roles, User and Cryptographic Officer (CO). The cryptographic module enforces the separation of roles using one authentication is allowed per module reset. Re-authentication is enforced when changing roles. Each operator must be assigned to a single role. Concurrent operators are NOT supported. An operator must log out before another operator can log in.

Table 7 lists all operator roles supported by the module. The Module does not support a maintenance role and bypass capability. The Module does not support concurrent operators. After the Module powers off or chip reset, all the data stored in internal memory (RAM), including previously authenticated operators, are cleared. All CSPs are protected through APIs and logic developed for the sole purpose of integration into specific HP host platforms. Only HP-authored drivers can access cryptographic APIs. Further, the Module functionally does not allow keys to be disclosed, modified, or substituted in FIPS mode of operation.

**Table 7 – Roles Description**

Role ID	Role Description	Authentication Type	Authentication Data
CO	Cryptographic Officer – The role assumed to perform cryptographic initialization or management functions.	Role-based	Operator certificate
User	User – The role assumed to perform general security services, including cryptographic operations and other approved security functions.	Role-based	Operator certificate

#### 3.2 Authentication Methods

##### Operator Certificate Authentication Method

An operator is assigned to a 256-bit unique key, it called “operator key”. The operator key is stored together with its role and identity string in non-volatile memory. The key is used to authenticate the operator when it logs in. It is the role and the identity string from the certificate that distinguishes each operator.

An operator also owns a unique operator certificate that consists of a role and an identity string, which is wrapped by the operator key using the procedure outlined by the NIST AES Key Wrap specification. Therefore the probability that a random attempt will succeed or a false acceptance depend on operator key. When the operator wants to log in, they send the certificate to the controller. The controller unwraps the certificate using the preloaded operator key. If the unwrap is successful and if the role and the identity string from the certificate both match the ones stored in the module, the operator authentication passes. The cryptographic services within the role are then activated.

Authentication requires **more** than 7.5ms (actual measured value).

**Table 8 – Authentication Description**

Authentication Method	Probability	Justification
Operator Certificate Authentication Method	$1/2^{256}$  The probability that a random attempt will succeed or a false acceptance will occur depends on 256-bit operator key. Therefore, the probability is $1/2^{256}$ , which is less than 1/1,000,000.	$8000/2^{256}$  Since authentication requires more than 7.5ms, in a worst case scenario, the Module can perform 8000 per minute. Therefore, the probability that multiple attacks within a given minute will be successful is $8000/2^{256}$ , which is less than 1/100,000.

**3.3 Services**

All services implemented by the Module are listed in the tables below. Each service description also describes all usage of CSPs by the service. Also, Table 9 shows the role that is able to perform the service.

**Table 9 – Authenticated Services**

Service	Description	CO	User
Configure	Configures parameters	X	
Operator Management	Adds an operator’s role, an identity string and an operator key, updates the operator key and zeroizes one or all operators and operator keys	X	X
Logout	Operator logout of the module	X	X
Execute encryption tests	Execute encryption tests for diagnostic purposes	X	
Decrypt	Decrypts data using XTS-AES		X
Encrypt	Encrypts data using XTS-AES		X
DEK Management	Updates and zeroizes DEKs	X	X
KEK Management	Updates and zeroizes KEKs	X	X
HMAC Key Management	Sets and zeroizes the HMAC key	X	X
Firmware Update	Updates the firmware	X	X

**Table 10 – Unauthenticated Services**

Service	Description
Module Reset (Self-test)	Reset the module
Login	Authenticates operators

Service	Description
Get Current Operator	Get the operator's role and an identity string of the current operator
Get Configuration	Get controller configuration parameters
Show Status	Show module status with LEDs or bits in a status register

Table 11 defines the relationship between access to CSPs and the different module services. The modes of access shown in the table are defined as:

- G = Generate: The Module generates the CSP. (But "G" is not used in the table below, because this module does not have any key generation function.)
- E = Execute: The Module executes using the CSP.
- W = Write: The Module writes the CSP. The write access is typically performed after a CSP is imported into the module, when the Module generates a CSP, or when the Module overwrites an existing CSP.
- Z = Zeroize: The Module zeroizes the CSP.

**Table 11 – CSP Access Rights within Services**

Service	CSPs				
	KEKini	KEK	DEK	Operator Key	HMAC Key
Configure					
Operator Management		E		W/Z	
Logout				E	
Execute encryption test					
Decrypt			E		
Encrypt			E		
DEK Management		E	W/Z		
KEK Management	E/W/Z	E/W/Z			
HMAC Key Management		E			W/Z
Firmware Update					E
Module Reset(Self-test)					
Login				E	
Get Current Operator					
Get Configuration					
Show Status					

## 4 Self-tests

Each time the Module is powered up it tests that the cryptographic algorithms still operate correctly and that sensitive data have not been damaged. Power up self-tests are available on demand by power cycling or resetting the Module.

On power up or reset, the Module performs self-tests described in Table 12 below. Firmware Integrity test and all KATs must be completed successfully prior to any other use of cryptography by the Module. If Firmware Integrity test or one of the KATs fails, the Module enters the fatal error state. The Module shows the result of self-tests with bits in a status register. If Firmware Integrity test fails, the two bits of the status register for “Image Loader Agent (ILA)” are set to “10”. In this case, the boot process is halted by the ILA. If one of the KATs fails, the two bits of the status register for “Encryption Capability” are set to “01”. In addition, from other eight bits of the register, it is known which cryptographic algorithm engine (AES, SHA or KWP) caused the error.

Self-tests do not require any intervention or input from the operator. Power up self-tests are automatically executed when the controller is powered up.

**Table 12 – Power Up Self-tests**

Test Target	Description
Firmware Integrity	32 bit CRC performed over all code in Flash memory.
AES	KATs: Encryption, Decryption Modes: ECB Key sizes: 256 bits
HMAC	KATs: Verification SHA sizes: SHA-1, SHA-224, SHA-256, SHA-384, SHA-512
XTS-AES mode	KATs: Encryption, Decryption Key sizes: 256 bits
AES Key Wrap	KATs: Wrap, Unwrap Key sizes: 256 bits

As the firmware is being externally sent to the controller, the firmware images are authenticated using the HMAC-SHA-256 authentication technique. Both a firmware image and the HMAC key are fed into the SHA engine, together with the proper SHA algorithm, the calculated HMAC digest is compared with the one embedded in the firmware image. If they don't equal, the firmware authentication fails and the Module indicate the state. If “Firmware Update” results in failure, the status field code of 0x0000000E is sent from the micro processor as the response. This code means “Firmware image HMAC authentication failure”. Conditional self-tests are automatically performed when an applicable security function or operation is invoked.

As the encryption test execute command is sent to the controller, the Module executes Cryptographic Algorithm Known Answer tests or HMAC test. The Cryptographic Algorithm Known Answer tests have positive test cases and negative ones. For a positive test case, the test passes if the result matches the known answer. For a negative test case, the result is expected to mismatch the known answer. For the HMAC test, the Module feeds the message and the HMAC key input from the host into the SHA engine, and returns the digest to the host. The command for Execute encryption test will change hardware configuration when running the Cryptographic Algorithm Known Answer tests or HMAC test. Therefore use it only for diagnostic purposes. To return to normal mode operations, execute a Module reset.

**Table 13 – Conditional Self-tests**

Test Target	Description
Firmware Load	HMAC authentication performed when firmware is loaded.
Encryption Engine Diagnosis	Cryptographic Algorithm Known Answer tests or HMAC test performed by command only when no active IOMBs.

## **5 Physical Security Policy**

The Module is a multi-chip embedded cryptographic module and conforms to Level 1 requirements for physical security. The cryptographic module consists of production-grade components.

## **6 Operational Environment**

The Module is designated as a limited operational environment under the FIPS 140-2 definitions. The Module includes a firmware load service to support necessary updates. New firmware versions within the scope of this validation must be validated through the FIPS 140-2 CMVP. Any other firmware loaded into this module is out of the scope of this validation and require a separate FIPS 140-2 validation.

## **7 Mitigation of Other Attacks Policy**

The Module does not mitigate other attacks.

## 8 Security Rules and Guidance

The Module design corresponds to the Module security rules. This section documents the security rules enforced by the cryptographic module to implement the security requirements of this FIPS 140-2 Level 1 module.

1. The Module shall provide two distinct operator roles: User and Cryptographic Officer.
2. The Module shall provide role-based authentication.
3. The Module shall clear previous authentications on power cycle.
4. When the Module has not been placed in a valid role, the operator shall not have access to any cryptographic services.
5. The operator shall be capable of commanding the Module to perform the power up self-tests by cycling power or resetting the Module.
6. Power up self-tests do not require any operator action.
7. Data output shall be inhibited during self-tests, zeroization, and error states.
8. Status information does not contain CSPs or sensitive data that if misused could lead to a compromise of the Module.
9. There are no restrictions on which keys or CSPs are zeroized by the zeroization service.
10. The Module does not support concurrent operators.
11. The Module does not support a maintenance interface or role.
12. The Module does not support manual key entry.
13. The Module does not have any external input/output devices used for entry/output of data.
14. The Module does not enter or output plaintext CSPs.
15. The Module does not support the update of the logical serial number or vendor ID.

### 8.1 Crypto Officer Guidance

The Crypto Officer must configure and enforce the following initialization procedures:

1. Verify that the name and part number of board is eSCAx WP820 B/xx(x: wild card). The eSCAx WP820 B/xx is the part number of the board that includes the module.
2. Verify that the firmware version of module is 02.09.28.00, 02.09.32.00 or 02.09.37.00.
3. Enable the encryption feature.
4. Configure encryption environmental settings.

The Module provides only FIPS-Approved mode of operation.

When the step mentioned above is completed, one KEK and two Operator Keys have been input into the module.

See [User Guide] Chapter 2 for detail of initialization procedures.

Otherwise, no specific commands or settings are required to place the Module in FIPS-approved mode of operation.

## **8.2 User Guidance**

The User must configure and enforce the following initialization procedures in order to operate in FIPS approved mode of operation:

1. Enable data encryption on the parity group.
2. Format the Volumes at the parity-group level.

See [User Guide] Chapter 4 for detail of initialization procedures.



## **9 Design Assurance Policy**

### **9.1 Configuration Management Overview**

Programs and documents are managed using a proprietary web-base configuration management system (Electric Stock System). Documents for validation and hardware components are managed by revision management by a proprietary ledger.

### **9.2 Installation, Initialization, and start-up Overview**

The procedure is described in section 8.1.

### **9.3 Secure Delivery and Operation Overview**

The Module shipped to customers from the factory or the distribution centers. The Module is delivered by the contracted carrier and unpacked by the contacted service personnel on site, and its contents are confirmed by the personnel.

## 10 References and Definitions

The following standards are referred to in this Security Policy.

**Table 14 – References**

Abbreviation	Full Specification Name
[FIPS140-2]	<i>Security Requirements for Cryptographic Modules</i> , May 25, 2001
[SP800-131A]	<i>Transitions: Recommendation for Transitioning the Use of Cryptographic Algorithms and Key Lengths</i> , January 2011
[SP800-38A]	<i>Recommendation for Block Cipher Modes of Operation Methods and Techniques</i> , 2001 Edition
[FIPS 198-1]	<i>The Keyed-Hash Message Authentication Code(HMAC)</i> , July 2008
[SP800-38E]	<i>Recommendation for Block Cipher Modes of Operation: The XTS-AES Mode for Confidentiality on Storage Devices</i> , January 2010
[IG D.9]	<i>Implementation Guidance for FIPS PUB 140-2 and the Cryptographic Module Validation Program, FIPS 140-2 Annex D - Approved Key Establishment Techniques, D.9 Key Transport Methods</i> , July 25, 2013
[AES Key Wrap Specification, Nov 2001]	<i>AES Key Wrap Specification</i> , November 16, 2001.
[User Guide]	<i>HP XP7 Encryption User Guide</i>

**Table 15 – Acronyms and Definitions**

Acronym	Definition
AES	Advanced Encryption Standard
CRC	Cyclic Redundancy Check
CSP	Critical Security Parameter
DEK	Data Encryption Key
FIPS	Federal Information Processing Standard
HMAC	Hash-based Message Authentication Code
KAT	Known Answer Test
KEK	Key Encryption Key
NIST	National Institute of Standards and Technology