

# NIST Interagency Report (IR) 8055

## Proof of Concept Implementation Demonstration

2015.09.09

*Certain commercial entities, equipment, or materials may be identified in this document in order to describe an experimental procedure or concept adequately. Such identification is not intended to imply recommendation or endorsement by NIST, nor is it intended to imply that the entities, materials, or equipment are necessarily the best available for the purpose.*

# Agenda

- Explanation of demonstration environment
- Demonstration of the Proof of Concept Implementation

# Technologies Used

- Microsoft Azure Infrastructure as a Service for Government
- Office 365 federated with Active Directory Federation Services (Windows Server 2012R2)
- Intercede MyID CMS, Kiosk, Identity Agent
- iTouch
- Windows Phone 8.1
- Windows 8.1 OS

# What are we demonstrating today?

- Issue a DPC on a mobile device
- Sign an email message with a DPC
- Authenticate to web application on mobile device using DPC
- Authentication to Office 365 Outlook Web Access (OWA)
- Outlook Client DPC authentication using Microsoft's modern authentication

# Experimental Environment

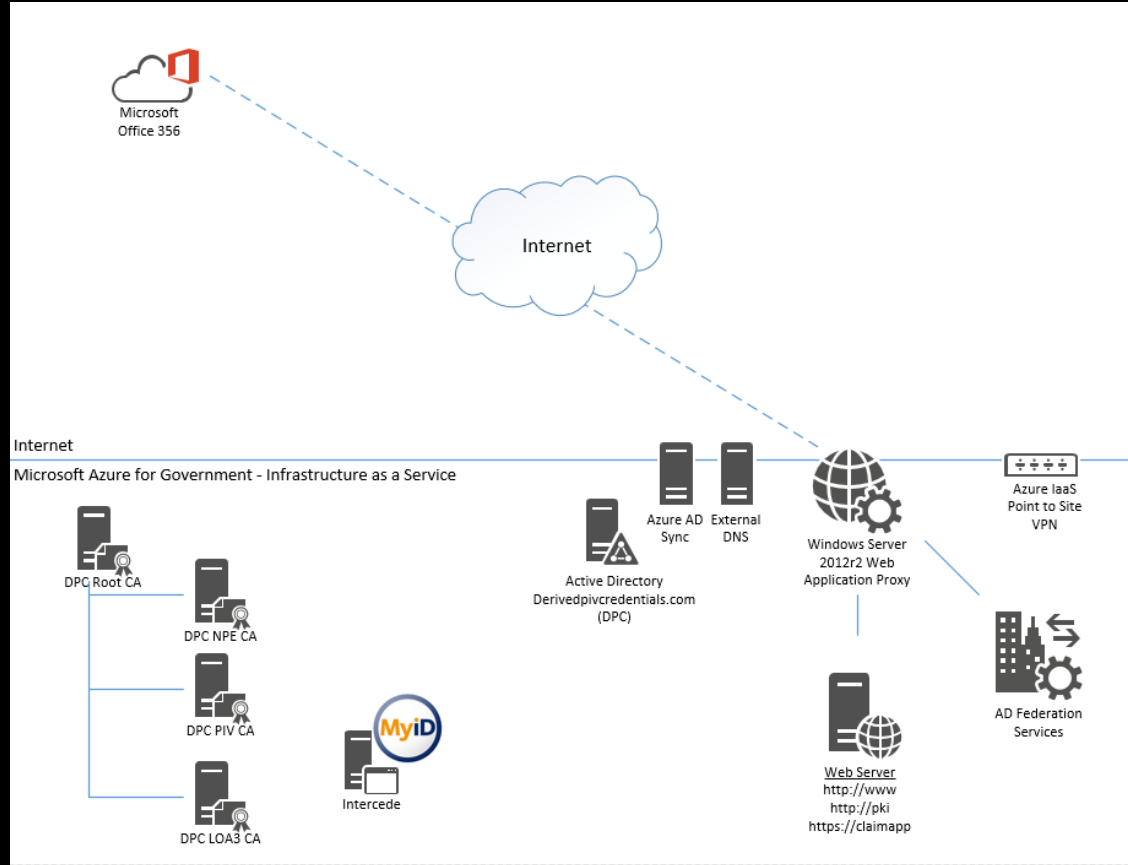

# Experimental Environment (Identity)

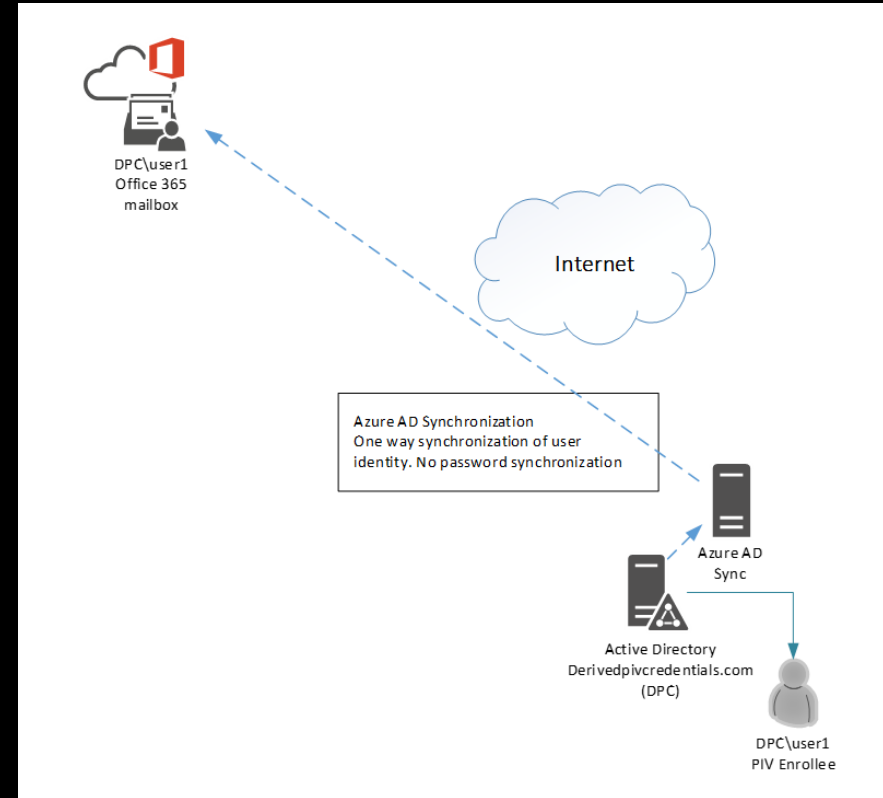
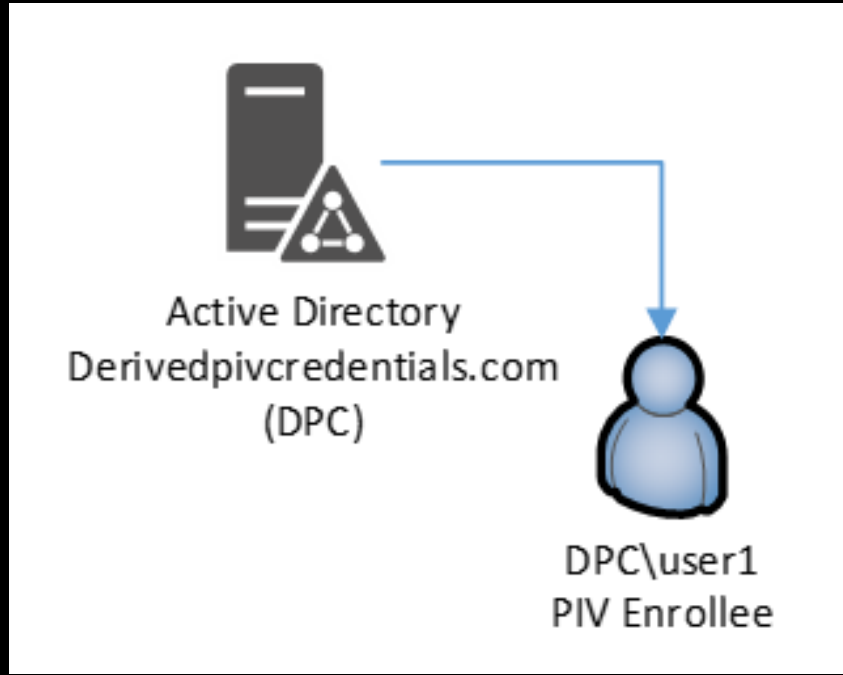

# Experimental Environment (Cloud Services)

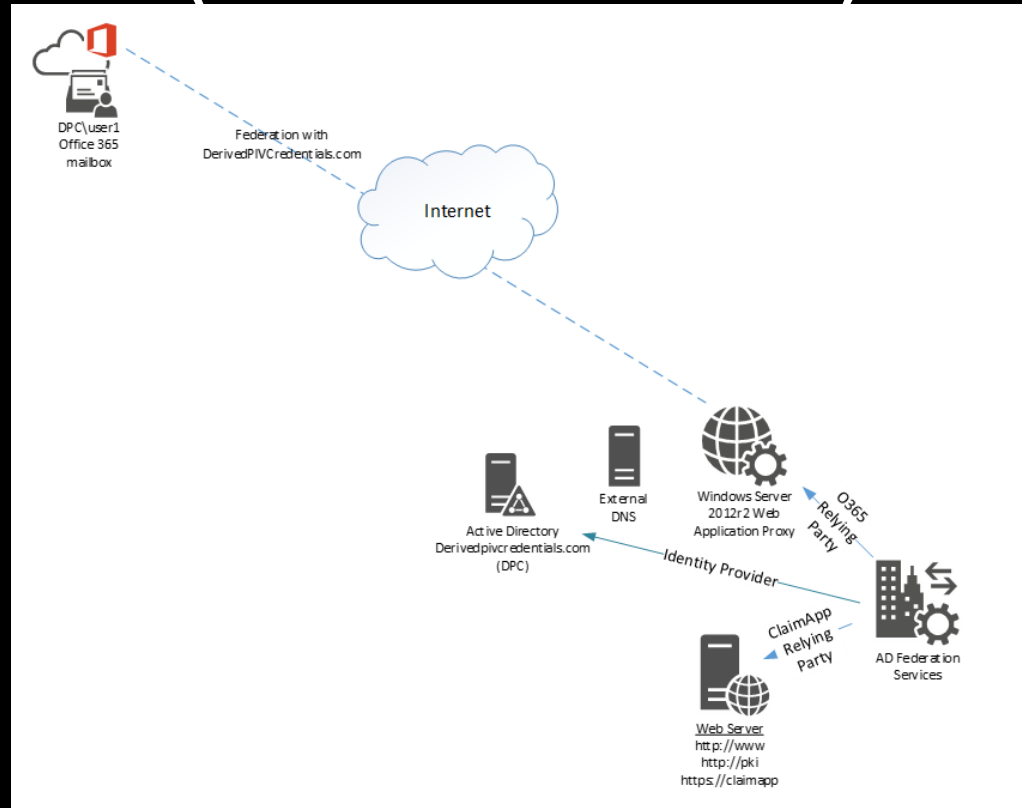



# Experimental Environment (PKI)

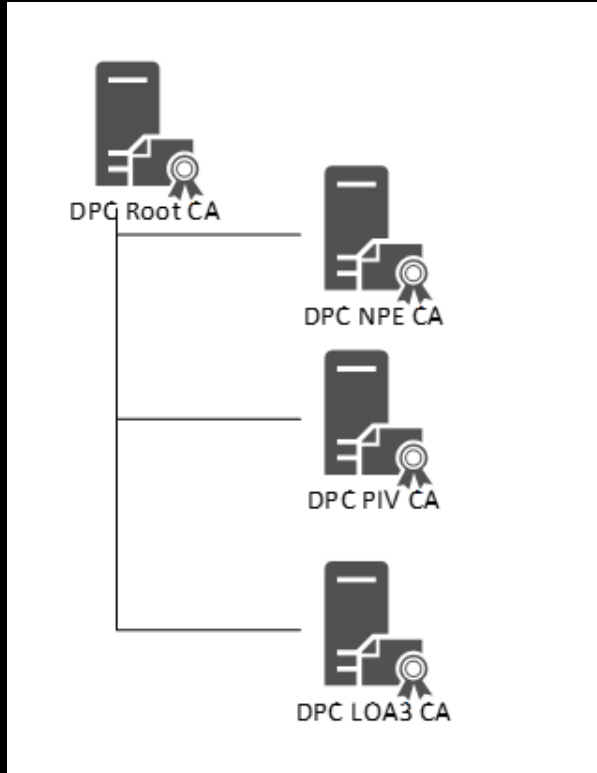

# Experimental Environment (Credential Management System)

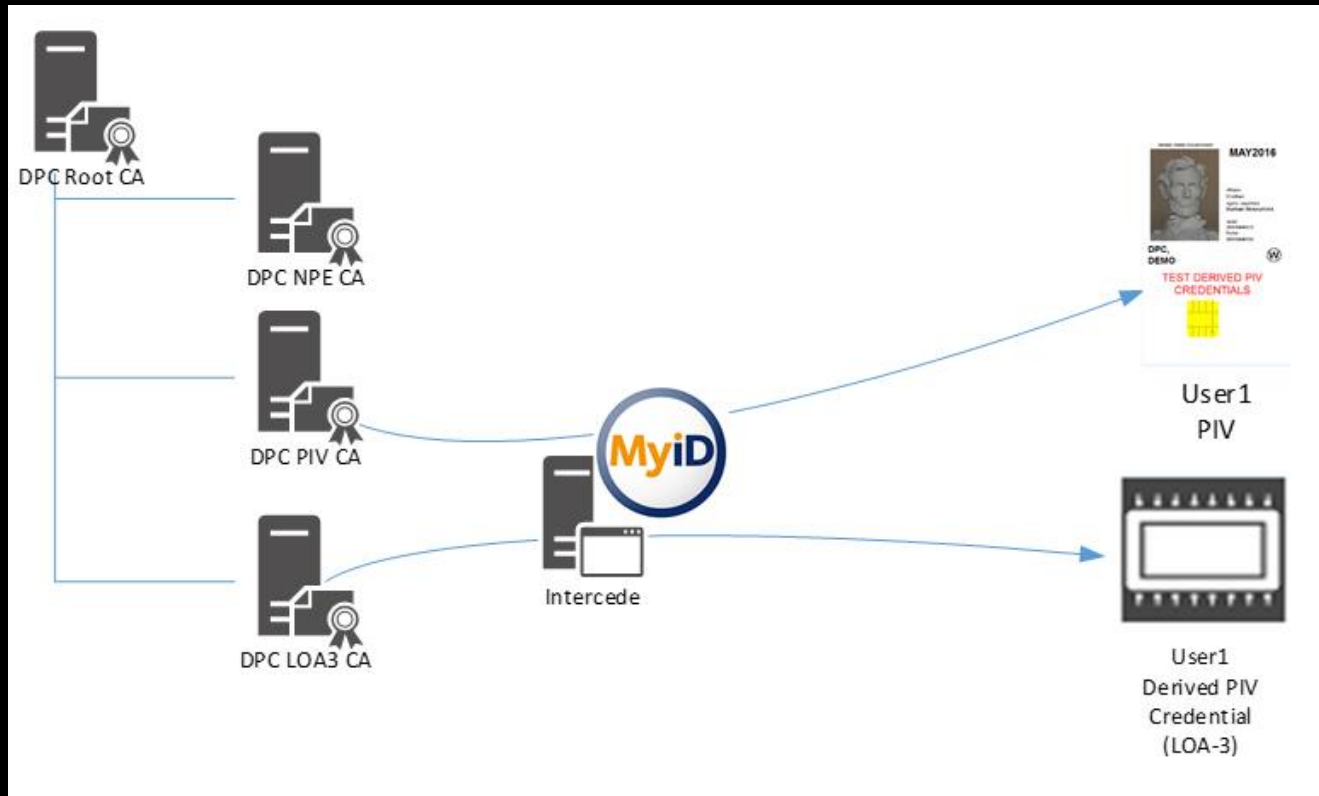

# Experimental Environment (Mobile Devices)

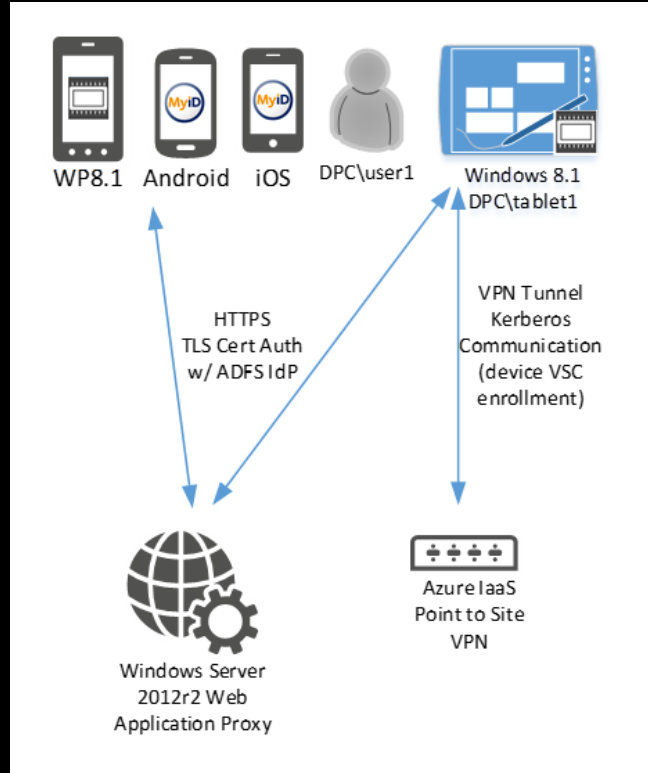

# Experimental Environment

