

Thank Goodness It's Friday (TGIF)

v1.0

Designers/Submitters (in alphabetical order):

Tetsu Iwata¹, Mustafa Khairallah², Kazuhiko Minematsu³
Thomas Peyrin², Yu Sasaki⁴, Siang Meng Sim², Ling Sun⁵

¹ Nagoya University, Japan
tetsu.iwata@nagoya-u.jp

² Nanyang Technological University, Singapore
mustafam001@e.ntu.edu.sg,
thomas.peyrin@ntu.edu.sg,
crypto.s.m.sim@gmail.com

³ NEC Corporation, Japan
k-minematsu@ah.jp.nec.com

⁴ NTT, Japan
sasaki.yu@lab.ntt.co.jp

⁵ Shandong University, China
lingsun@mail.sdu.edu.cn

Contents

1	Introduction	2
2	Specification	4
2.1	Notations	4
2.2	Parameters	5
2.3	Recommended Parameter Sets	5
2.4	The Tweakable Block Cipher TGIF-TBC	6
2.5	The Authenticated Encryption TGIF	9
3	Security Claims	19
4	Security Analysis	21
4.1	Security of the mode	21
4.2	Security of TGIF-TBC	23
5	Features	27
6	Design Rationale	30
6.1	TGIF-TBC Design	30
6.2	Mode Design	31
7	Implementations	37
7.1	Software Performances	37
7.2	ASIC Performances	37
8	Appendix	43
8.1	Domain Separation	43
9	Changelog	44

Introduction

This document specifies TGIF, an authenticated encryption with associated data (AEAD) scheme based on a tweakable block cipher (TBC) TGIF-TBC. TGIF consists of two families, a nonce-based AE (NAE) TGIF-N and a nonce misuse-resistant AE (MRAE) TGIF-M. TGIF aims at lightweight, efficient, and highly-secure NAE and MRAE schemes, based on a TBC.

As the underlying TBC, we propose TGIF-TBC, a new lightweight TBC strongly inspired from GIFT cipher [2]. More precisely, TGIF-TBC can be seen as an improvement over the 128-bit version of GIFT cipher, by providing improved performances, improved security guarantees, and enabling tweak capabilities. We end up with an extremely efficient cipher, from very constrained hardware to high-end software.

The operating mode used in TGIF is taken from the Remus submission [18], which is derived from another submission Romulus [19]. Remus strongly minimizes the area overhead on top of the internal TBC while having good throughput thanks to rate-1 operation. Here, the internal TBC is not directly instantiated by TGIF-TBC, instead there is a mode called ICE applied to TGIF-TBC (by taking it as a block cipher) to implement a TBC. This enables to reduce the size of the overall scheme, at the cost of security proof relying on the ideal-cipher model. It provides classical $n/2$ -bit security to full n -bit security and can very easily switch from nonce-respecting mode to nonce-misuse resistant mode.

We specify a set of members for TGIF that have different TBC (ICE) instantiations based on a block cipher (taking TGIF-TBC as a block cipher) in order to provide security-efficiency trade-offs.

The overall structure of TGIF-N shares similarity in part with a (TBC-based variant of) block cipher mode COFB [10, 12], yet, we make numerous refinements to achieve our design goal. Consequently, as a mode of TBC ICE, TGIF-N achieves a significantly smaller state size than Θ CB3 [25], the typical choice for TBC-based AE mode, while keeping the equivalent efficiency (*i.e.*, the same number of TBC calls). Also TGIF-N is inverse-free (*i.e.*, no TBC decryption routine is needed) unlike Θ CB3. For security, it allows either classical $n/2$ -bit security or full n -bit security depending on the variant of ICE, for $n = 128$ being the block size of TGIF-TBC. The difference in ICE gives a security-area trade off, and 128-bit secure variant (TGIF-N2) has the bit security equivalent to Θ CB3.

To see the superior performance of TGIF-N, let us compare n -bit secure TGIF-N2 with other size-oriented and n -bit secure AE schemes, such as conventional permutation-based AEs using $3n$ -bit permutation with n -bit rate. Both have $3n$ state bits and process n -bit message per primitive call. However, the cryptographic primitive for TGIF-N2 is expected to be much more lightweight and/or faster because of smaller output size ($3n$ vs n bits). Moreover, our primitive has only n -bit tweakable, hence it is even smaller than the members of Romulus; they are n -bit secure and using tweakable state of $2n$ or $3n$ bits. Both permutation-based schemes and TGIF rely on non-standard models (random permutation or ideal-cipher), and we emphasize that the security of TGIF-TBC inside TGIF has been comprehensively evaluated, not only for the single-key related-tweak setting

but also related-tweakey setting, which suggests strong reliability to be used as the ideal-cipher.

An additional feature of TGIF is that it offers a very flexible security/size trade-off without changing the throughput. In more detail, TGIF contains $n/2$ -bit secure variants (TGIF-N1 and TGIF-M1) and n -bit secure variants (TGIF-N2 and TGIF-M2). Their difference is only in the existence of the second (block) mask, which increases the state size. If the latter is too big and n -bit security is overkill, it is possible to derive an intermediate variant by truncating the second mask to (say) $n/2$ bits. It will be $(n + n/2)/2 = 3n/4$ -bit secure. For simplicity, we did not include such variants in the official members of TGIF, however, this flexibility would be useful in practice.

TGIF-M follows the general construction of MRAE called SIV [39]. TGIF-M reuses the components of TGIF-N as much as possible, and TGIF-M is simply obtained by processing message twice by TGIF-N. TGIF-M has an efficiency advantage over misuse-resistant variants of Romulus (Romulus-M). In particular, the high-security variant (TGIF-M2) achieves n -bit security against nonce-respecting adversaries and $n/2$ -bit security against nonce-misusing adversaries, which shows an equivalent level of security of Romulus-M to SCT [35]. Thanks to the shared components, most of the advantages of TGIF-N mentioned above also hold for TGIF-M.

We present a detailed comparison of TGIF with other AE candidates in Section 6.

Organization of the document. In Section 2, we first introduce the basic notations and the notion of tweakable block cipher, followed by the list of parameters for TGIF, the recommended parameter sets, and the specification of TBC TGIF-TBC. In the last part of Section 2, we specify two families of TGIF, TGIF-N and TGIF-M. We present our security claims in Section 3 and show our security analysis of TGIF-TBC in Section 4. In Section 5, we describe the desirable features of TGIF. The design rationale under our schemes, including some details of modes and choice of the TBC, is presented in Section 6. Finally, we show some implementation aspects of TGIF in Section 7.

Specification

2.1 Notations

Let $\{0, 1\}^*$ be the set of all finite bit strings, including the empty string ε . For $X \in \{0, 1\}^*$, let $|X|$ denote its bit length. Here $|\varepsilon| = 0$. For integer $n \geq 0$, let $\{0, 1\}^n$ be the set of n -bit strings, and let $\{0, 1\}^{\leq n} = \bigcup_{i=0, \dots, n} \{0, 1\}^i$, where $\{0, 1\}^0 = \{\varepsilon\}$. Let $\llbracket n \rrbracket = \{1, \dots, n\}$ and $\llbracket n \rrbracket_0 = \{0, 1, \dots, n-1\}$.

For two bit strings X and Y , $X \parallel Y$ is their concatenation. We also write this as XY if it is clear from the context. Let 0^i be the string of i zero bits, and for instance we write 10^i for $1 \parallel 0^i$. We denote $\text{msb}_x(X)$ (resp. $\text{lsb}_x(X)$) the truncation of X to its x most (resp. least) significant bits. See “Endian” paragraph below. Bitwise XOR of two variables X and Y is denoted by $X \oplus Y$, where $|X| = |Y| = c$ for some integer c . By convention, if one of X or Y is represented as an integer in $\llbracket 2^c \rrbracket_0$ we assume a standard integer-to-binary encoding: for example $X \oplus 1$ denotes $X \oplus 0^{c-1}1$.

Padding. For $X \in \{0, 1\}^{\leq l}$ of length multiple of 8 (*i.e.*, byte string),

$$\text{pad}_l(X) = \begin{cases} X & \text{if } |X| = l, \\ X \parallel 0^{l-|X|-8} \parallel \text{len}_8(X), & \text{if } 0 \leq |X| < l, \end{cases}$$

where $\text{len}_8(X)$ denotes the one-byte encoding of the byte-length of X . Here, $\text{pad}_l(\varepsilon) = 0^l$. When $l = 128$, $\text{len}_8(X)$ has 16 variations (*i.e.*, byte length 0 to 15), and we encode it to the last 4 bits of $\text{len}_8(X)$ (for example, $\text{len}_8(11) = 00001011$). The case $l = 64$ is similarly treated, by using the last 3 bits.

Parsing. For $X \in \{0, 1\}^*$, let $|X|_n = \max\{1, \lceil |X|/n \rceil\}$. Let $(X[1], \dots, X[x]) \stackrel{r}{\leftarrow} X$ be the parsing of X into n -bit blocks. Here $X[1] \parallel X[2] \parallel \dots \parallel X[x] = X$ and $x = |X|_n$. When $X = \varepsilon$ we have $X[1] \stackrel{r}{\leftarrow} X$ and $X[1] = \varepsilon$. Note in particular that $|\varepsilon|_n = 1$.

Galois Field. An element a in the Galois field $\text{GF}(2^n)$ will be interchangeably represented as an n -bit string $a_{n-1} \dots a_1 a_0$, a formal polynomial $a_{n-1}x^{n-1} + \dots + a_1x + a_0$, or an integer $\sum_{i=0}^{n-1} a_i 2^i$.

Matrix. Let G be an $n \times n$ binary matrix defined over $\text{GF}(2)$. For $X \in \{0, 1\}^n$, let $G(X)$ denote the matrix-vector multiplication over $\text{GF}(2)$, where X is interpreted as a column vector. We may write $G \cdot X$ instead of $G(X)$.

Endian. We employ little endian for byte ordering: an n -bit string X is received as

$$X_7X_6 \dots X_0 \parallel X_{15}X_{14} \dots X_8 \parallel \dots \parallel X_{n-1}X_{n-2} \dots X_{n-8},$$

where X_i denotes the $(i + 1)$ -st bit of X (for $i \in \llbracket n \rrbracket_0$). Therefore, when c is a multiple of 8 and X is a byte string, $\text{msb}_c(X)$ and $\text{lsb}_c(X)$ denote the last (rightmost) c bytes of X and the first (leftmost) c bytes of X , respectively. For example, $\text{lsb}_{16}(X) = (X_7X_6 \dots X_0 \parallel X_{15}X_{14} \dots X_8)$ and $\text{msb}_8(X) = (X_{n-1}X_{n-2} \dots X_{n-8})$ with the above X . Since our specification is defined over byte strings, we only consider the above case for msb and lsb functions (*i.e.*, the subscript c is always a multiple of 8).

(Tweakable) Block Cipher. A tweakable block cipher (TBC) is a keyed function $\tilde{E} : \mathcal{K} \times \mathcal{T}_W \times \mathcal{M} \rightarrow \mathcal{M}$, where \mathcal{K} is the key space, \mathcal{T}_W is the tweak space, and $\mathcal{M} = \{0, 1\}^n$ is the message space, such that for any $(K, T_w) \in \mathcal{K} \times \mathcal{T}_W$, $\tilde{E}(K, T_w, \cdot)$ is a permutation over \mathcal{M} . We interchangeably write $\tilde{E}(K, T_w, M)$ or $\tilde{E}_K(T_w, M)$ or $\tilde{E}_K^{T_w}(M)$. When \mathcal{T}_W is singleton, it is essentially a block cipher and is simply written as $E : \mathcal{K} \times \mathcal{M} \rightarrow \mathcal{M}$.

2.2 Parameters

TGIF has the following parameters:

- Nonce length $nl = 128$.
- Key length $k = 128$.
- Message and AD block length $n = 128$.
- Mode to convert a block cipher into a TBC, $\text{ICmode} \in \{\text{ICE1}, \text{ICE2}\}$.
- Counter bit length $d = 128$. *Counter* refers the part of the tweakkey that changes after each TBC call, for the same (N, K) pair. Each variants of TGIF has $2^d - 1$ possible counter values for each (N, K) pair.
- Tag length $\tau = n$.

The block cipher $E : \mathcal{K} \times \mathcal{M} \rightarrow \mathcal{M}$ with $\mathcal{M} = \{0, 1\}^{128}$ and $\mathcal{K} = \{0, 1\}^{128}$. Here, E is TGIF-TBC, by seeing the whole tweakkey space as the key space, and assuming certain tweakkey encodings specified in Section 2.4.

While our submission fixes $\tau = n$, a tag for NAE schemes can be truncated if needed (not for MRAE), at the cost of decreased security against forgery. See Section 4.

NAE and MRAE families. TGIF has two families, TGIF-N and TGIF-M, and each family consists of two members (the sets of parameters). The former implements nonce-based AE (NAE) secure against Nonce-respecting adversaries, and the latter implements nonce Misuse-resistant AE (MRAE) introduced by Rogaway and Shrimpton [39]. The name TGIF stands for the set of two families.

2.3 Recommended Parameter Sets

We present our members (parameters) in Table 2.1. The primary member of our submission is TGIF-N1. All members conform to the requirements of NIST call for proposal with respect to key length, nonce length, and maximum input length.

Table 2.1: Members of TGIF.

Family	Name	E	ICmode	k	nl	n	d	τ
TGIF-N	TGIF-N1	TGIF-TBC	ICE1	128	128	128	128	128
	TGIF-N2	TGIF-TBC	ICE2	128	128	128	128	128
TGIF-M	TGIF-M1	TGIF-TBC	ICE1	128	128	128	128	128
	TGIF-M2	TGIF-TBC	ICE2	128	128	128	128	128

2.4 The Tweakable Block Cipher TGIF-TBC

In this section, we describe our tweakable block-cipher TGIF-TBC. It has a single version: the tweaky state is 128 bits, while the plaintext/ciphertext is also 128 bits. We omit the description of its inverse as all its component are trivial to invert.

TGIF-TBC is an iterative Substitution-Permutation Network (SPN) based TBC, composed of 18 steps. It is largely inspired by GIFT-64 and GIFT-128 ciphers [2]. Indeed, TGIF-TBC will reuse 4 rounds of GIFTb as a black box, while GIFTb is a slight variation of GIFT-64 where the data arrives in bitslice form (the (twea)key schedule is also changed). There are different ways to perceive GIFT-64, but the more pictorial description is detailed in the GIFT paper, which looks like a larger version of PRESENT cipher with 32 4-bit S-boxes and a 128-bit permutation (see Figure 1 of [2]).

Initialisation

The 128-bit state of TGIF-TBC is thus viewed as two words L and R of 64-bit each, each of these words seen in turn as four 16-bit words $L_0, L_1, L_2, L_3, R_0, R_1, R_2$ and R_3 . We load the incoming plaintext bytes B_0, \dots, B_{15} in L_0 first, then L_1 , etc., finishing with R_3 .

$$L = \begin{cases} L_0 &= B_1 || B_0 \\ L_1 &= B_3 || B_2 \\ L_2 &= B_5 || B_4 \\ L_3 &= B_7 || B_6 \end{cases} \quad R = \begin{cases} R_0 &= B_9 || B_8 \\ R_1 &= B_{11} || B_{10} \\ R_2 &= B_{13} || B_{12} \\ R_3 &= B_{15} || B_{14} \end{cases}$$

The 128-bit tweaky state KS is viewed as four words TK_0, TK_1, TK_2 and TK_3 of 32-bit each. We load the incoming tweaky bytes K_0, \dots, K_{15} in TK_0 first, then TK_1 , etc., finishing with TK_3 .

$$TK = \begin{cases} TK_0 &= K_3 || K_2 || K_1 || K_0 \\ TK_1 &= K_7 || K_6 || K_5 || K_4 \\ TK_2 &= K_{11} || K_{10} || K_9 || K_8 \\ TK_3 &= K_{15} || K_{14} || K_{13} || K_{12} \end{cases}$$

Round function of GIFTb

TGIF-TBC will use 4 rounds of a bitslice version of GIFT-64 as black box (that is, GIFT-64 with the data arriving in bitslice mode instead, we denote this cipher GIFTb), denoted $\text{GIFTb}_4(S, TK)$ where S is a 64-bit state composed of four 16-bit words S_0, S_1, S_2 and S_3 , and where TK is the 128-bit tweaky state. Each round of GIFT-64 consists of 4 steps: AddRoundTweakey, AddConstant, SubCells and PermBits. We use a new bitslice representation to

Table 2.2: Constants used in TGIF-TBC

Step	Constants			
	round 0	round 1	round 2	round 3
0 - 3	01,02,04,08	10,20,40,03	06,0c,18,30	60,43,05,0a
4 - 7	14,28,50,23	46,0f,1e,3c	78,73,65,49	11,22,44,0b
8 - 11	16,2c,58,33	66,4f,1d,3a	74,6b,55,29	52,27,4e,1f
12 - 15	3e,7c,7b,75	69,51,21,42	07,0e,1c,38	70,63,45,09
16 - 17		12,24,48,13	26,4c,1b,36	

AddRoundTweakey. This step consists of adding the subtweakey word TK_0 to S_0 and to S_1 : $S_0 = S_0 \oplus TK_0$ and $S_1 = S_1 \oplus (TK_0) \gg 16$. Then the tweakey schedule function is applied to the tweakey state (see description below).

AddConstant. This step consists of XORing the least significant bits of state S_3 with 7-bit round dependant constants c_i (given in Table 2.2) and swapping the most significant bit of S_3 : $S_3 = S_3 \oplus c_i \oplus 0x8000$. These constants have been generated with a 7-bit maximum-length LFSR initialised to 1. Let $x_6, x_5, x_4, x_3, x_2, x_1, x_0$ be the input seven bits (x_0 being the LSB), then after clocking the LFSR we obtain: $x_5, x_4, x_3, x_2, x_1, x_0 \oplus x_6, x_6$.

SubCells. Update the cipher state with the following instructions:

$$\begin{aligned}
S_1 &\leftarrow S_1 \oplus (S_0 \& S_2) \\
S_0 &\leftarrow S_0 \oplus (S_1 \& S_3) \\
S_2 &\leftarrow S_2 \oplus (S_0 | S_1) \\
S_3 &\leftarrow S_3 \oplus S_2 \\
S_1 &\leftarrow S_1 \oplus S_3 \\
S_3 &\leftarrow \sim S_3 \\
S_2 &\leftarrow S_2 \oplus (S_0 \& S_1) \\
\{S_0, S_1, S_2, S_3\} &\leftarrow \{S_3, S_1, S_2, S_0\},
\end{aligned}$$

where $\&$, $|$ and \sim are 16-bit wise AND, OR and NOT operations respectively.

PermBits. Different 16-bit bit permutations are applied to each S_i independently.

In the first round, we apply to S_i a right rotation of i positions inside each 4-bit subwords (note that S_0 is thus not modified):

$$\begin{aligned}
S_0 &: (15, 14, 13, 12, 11, 10, 9, 8, 7, 6, 5, 4, 3, 2, 1, 0) \mapsto (15, 14, 13, 12, 11, 10, 9, 8, 7, 6, 5, 4, 3, 2, 1, 0) \\
S_1 &: (15, 14, 13, 12, 11, 10, 9, 8, 7, 6, 5, 4, 3, 2, 1, 0) \mapsto (12, 15, 14, 13, 8, 11, 10, 9, 4, 7, 6, 5, 0, 3, 2, 1) \\
S_2 &: (15, 14, 13, 12, 11, 10, 9, 8, 7, 6, 5, 4, 3, 2, 1, 0) \mapsto (13, 12, 15, 14, 9, 8, 11, 10, 5, 4, 7, 6, 1, 0, 3, 2) \\
S_3 &: (15, 14, 13, 12, 11, 10, 9, 8, 7, 6, 5, 4, 3, 2, 1, 0) \mapsto (14, 13, 12, 15, 10, 9, 8, 11, 6, 5, 4, 7, 2, 1, 0, 3)
\end{aligned}$$

In the second round, we apply to S_i a right rotation of $4i$ positions inside the entire 16-bit word (note that S_0 is thus not modified):

$$\begin{aligned}
S_0 &: (15, 14, 13, 12, 11, 10, 9, 8, 7, 6, 5, 4, 3, 2, 1, 0) \mapsto (15, 14, 13, 12, 11, 10, 9, 8, 7, 6, 5, 4, 3, 2, 1, 0) \\
S_1 &: (15, 14, 13, 12, 11, 10, 9, 8, 7, 6, 5, 4, 3, 2, 1, 0) \mapsto (3, 2, 1, 0, 15, 14, 13, 12, 11, 10, 9, 8, 7, 6, 5, 4) \\
S_2 &: (15, 14, 13, 12, 11, 10, 9, 8, 7, 6, 5, 4, 3, 2, 1, 0) \mapsto (7, 6, 5, 4, 3, 2, 1, 0, 15, 14, 13, 12, 11, 10, 9, 8) \\
S_3 &: (15, 14, 13, 12, 11, 10, 9, 8, 7, 6, 5, 4, 3, 2, 1, 0) \mapsto (11, 10, 9, 8, 7, 6, 5, 4, 3, 2, 1, 0, 15, 14, 13, 12)
\end{aligned}$$

In the third round, we apply to S_i a left rotation of i positions inside each 4-bit subwords (note that S_0 is thus not modified):

$$\begin{aligned} S_0 &: (15, 14, 13, 12, 11, 10, 9, 8, 7, 6, 5, 4, 3, 2, 1, 0) \mapsto (15, 14, 13, 12, 11, 10, 9, 8, 7, 6, 5, 4, 3, 2, 1, 0) \\ S_1 &: (15, 14, 13, 12, 11, 10, 9, 8, 7, 6, 5, 4, 3, 2, 1, 0) \mapsto (14, 13, 12, 15, 10, 9, 8, 11, 6, 5, 4, 7, 2, 1, 0, 3) \\ S_2 &: (15, 14, 13, 12, 11, 10, 9, 8, 7, 6, 5, 4, 3, 2, 1, 0) \mapsto (13, 12, 15, 14, 9, 8, 11, 10, 5, 4, 7, 6, 1, 0, 3, 2) \\ S_3 &: (15, 14, 13, 12, 11, 10, 9, 8, 7, 6, 5, 4, 3, 2, 1, 0) \mapsto (12, 15, 14, 13, 8, 11, 10, 9, 4, 7, 6, 5, 0, 3, 2, 1) \end{aligned}$$

In the fourth round, we apply to S_i a left rotation of $4i$ positions inside the entire 16-bit word (note that S_0 is thus not modified):

$$\begin{aligned} S_0 &: (15, 14, 13, 12, 11, 10, 9, 8, 7, 6, 5, 4, 3, 2, 1, 0) \mapsto (15, 14, 13, 12, 11, 10, 9, 8, 7, 6, 5, 4, 3, 2, 1, 0) \\ S_1 &: (15, 14, 13, 12, 11, 10, 9, 8, 7, 6, 5, 4, 3, 2, 1, 0) \mapsto (11, 10, 9, 8, 7, 6, 5, 4, 3, 2, 1, 0, 15, 14, 13, 12) \\ S_2 &: (15, 14, 13, 12, 11, 10, 9, 8, 7, 6, 5, 4, 3, 2, 1, 0) \mapsto (7, 6, 5, 4, 3, 2, 1, 0, 15, 14, 13, 12, 11, 10, 9, 8) \\ S_3 &: (15, 14, 13, 12, 11, 10, 9, 8, 7, 6, 5, 4, 3, 2, 1, 0) \mapsto (3, 2, 1, 0, 15, 14, 13, 12, 11, 10, 9, 8, 7, 6, 5, 4) \end{aligned}$$

There is an interesting property that after these 4 rounds of permutations, the bits in each S_i returns to its initial position. E.g. For S_1 , applying the 4 rounds of operation, we get

$$\begin{aligned} S_1 &: (15, 14, 13, 12, 11, 10, 9, 8, 7, 6, 5, 4, 3, 2, 1, 0) \mapsto (12, 15, 14, 13, 8, 11, 10, 9, 4, 7, 6, 5, 0, 3, 2, 1) \\ &\mapsto (0, 3, 2, 1, 12, 15, 14, 13, 8, 11, 10, 9, 4, 7, 6, 5) \\ &\mapsto (3, 2, 1, 0, 15, 14, 13, 12, 11, 10, 9, 8, 7, 6, 5, 4) \\ &\mapsto (15, 14, 13, 12, 11, 10, 9, 8, 7, 6, 5, 4, 3, 2, 1, 0) \end{aligned}$$

Step function of TGIF-TBC

The step function applies iteratively a MISTY structure [29]. Let L and R be the two 64-bit left and right internal states, then each step of TGIF-TBC will perform:



Figure 2.1: The step function of TGIF-TBC.

where TK is the current tweakey state. We recall that the tweakey state is updated every round inside GIFTb_4 with the tweakey schedule.

Tweakey schedule of TGIF-TBC

The tweakey state, decomposed as $TK = TK_0 || TK_1 || TK_2 || TK_3$ is updated as follows:

$$\begin{cases} TK'_0 &= TK_1 \\ TK'_1 &= TK_2 \\ TK'_2 &= TK_3 \\ TK'_3 &= TK_0 \oplus TK_1 \oplus ((TK_3 \oplus 1) \lll 8) \oplus 1 \end{cases}$$

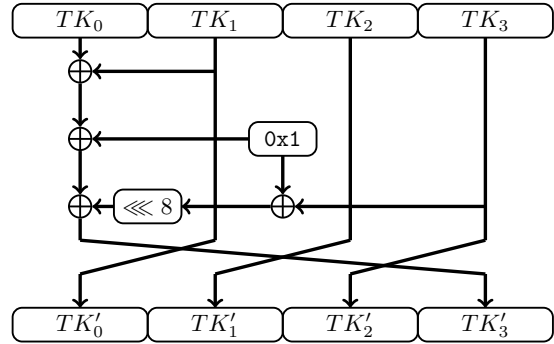

Figure 2.2: The TGIF-TBC tweakkey schedule

This is basically a simple generalised Feistel construction with a linear update function. It has the special property to cycle every 24 calls, and will thus cycle at the end of the cipher (every 72 rounds, or 18 steps). In other words, the first and last key states are identical.

Finalisation

The final value of the internal state array provides the ciphertext with cells being unpacked in the same way as the packing during initialization. Test vectors for TGIF-TBC are provided below.

Key: 00 01 02 03 04 05 06 07 08 09 0A 0B 0C 0D 0E 0F
 Plaintext: 00 01 02 03 04 05 06 07 08 09 0A 0B 0C 0D 0E 0F
 Ciphertext: F6 1B 94 03 28 C7 58 B6 90 A6 5A B1 03 4B 9B B7

Key: 3A E8 AF 4B C5 88 01 5C 24 C6 48 BC 2C 1C CD E5
 Plaintext: AC 3B C6 DC 0D 10 08 1E CE 8C B4 E3 28 B2 DD D5
 Ciphertext: 2E A6 0D BE F6 38 09 F9 80 34 F4 AF 3A DE 28 D9

2.5 The Authenticated Encryption TGIF

2.5.1 Block Counters and Domain Separation

Domain separation. We will use a domain separation byte B to ensure appropriate independence between the tweakable block cipher calls and the various versions of TGIF. Let $B = (b_7 || b_6 || b_5 || b_4 || b_3 || b_2 || b_1 || b_0)$ be the bitwise representation of this byte, where b_7 is the MSB and b_0 is the LSB (see also Figure 2.3). Then, we have the following:

- $b_6 b_5$ will specify the parameter sets. They are fixed to: 00 for TGIF-N1, 01 for TGIF-M1, 10 for TGIF-N2, 11 for TGIF-M2. Note that all nonce-respecting modes have $b_5 = 0$ and all nonce-misuse resistant modes have $b_5 = 1$.
- b_7 and b_4 are set to 0.
- b_3 is set to 1 once we have handled the last block of data (AD and message chains are treated separately), to 0 otherwise.
- b_2 is set to 1 when we are performing the authentication phase of the operating mode (*i.e.*, when no ciphertext data is produced), to 0 otherwise. In the special case where $b_5 = 1$ and $b_4 = 1$ (*i.e.*, last block for the nonce-misuse mode), b_3 will instead denote if the number of message blocks is even ($b_3 = 1$ if that is the case, 0 otherwise).

- b_1 is set to 1 when we are handling a message block, to 0 otherwise. Note that in the case of the misuse-resistant modes, the message blocks will be used during authentication phase (in which case we will have $b_3 = 1$ and $b_2 = 1$). In the special case where $b_5 = 1$ and $b_4 = 1$ (*i.e.*, last block for the nonce-misuse mode), b_3 will instead denote if the number of message blocks is even ($b_5 = 1$ if that is the case, 0 otherwise).
- b_0 is set to 1 when we are handling a padded block (associated data or message), to 0 otherwise.

The reader can refer to Table 8.1 in the Appendix to obtain the exact specifications of the domain separation values depending on the various cases.

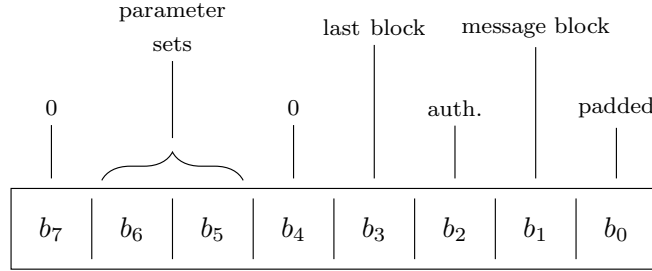

Figure 2.3: Domain separation when using the tweakable block cipher

Doubling over a Finite Field. For any positive integer c , we assume $\text{GF}(2^c)$ is defined over the lexicographically-first polynomial among the irreducible degree c polynomials of a minimum number of coefficients. We use single field: $\text{GF}(2^c)$ for $c = 128$. The primitive polynomial is:

$$\mathbf{x}^{128} + \mathbf{x}^7 + \mathbf{x}^2 + \mathbf{x} + 1 \text{ for } c = 128.$$

Let $Z = (z_{c-1}z_{c-2} \dots z_1z_0)$ for $z_i \in \{0, 1\}$, $i \in \llbracket c \rrbracket_0$ be an element of $\text{GF}(2^c)$. A multiplication of Z by the generator (polynomial \mathbf{x}) is called *doubling* and written as $2Z$ [37]. An i -times doubling of Z is written as 2^iZ , and is efficiently computed from $2^{i-1}Z$ (see below). Here, $2^0Z = Z$ for any Z . When $Z = 0^n$, *i.e.*, zero entity in the field, then $2^iZ = 0^n$ for any $i \geq 0$.

To avoid confusion, we may write \overline{D} (in particular when it appears in a part of tweak) in order to emphasize that this is indeed a doubling-based counter, *i.e.*, $2^D X$ for some key-dependent variable X . One can interpret \overline{D} as 2^D (but in that case it is a part of tweakey state or a coefficient of mask, and *not* a part of input of ICE).

On bit-level, doubling $Z \rightarrow 2Z$ over $\text{GF}(2^c)$ for $c = 128$ is defined as

$$\begin{aligned} z_i &\leftarrow z_{i-1} \text{ for } i \in \llbracket 128 \rrbracket_0 \setminus \{7, 2, 1, 0\}, \\ z_7 &\leftarrow z_6 \oplus z_{127}, \\ z_2 &\leftarrow z_1 \oplus z_{127}, \\ z_1 &\leftarrow z_0 \oplus z_{127}, \\ z_0 &\leftarrow z_{127}. \end{aligned}$$

2.5.2 The TBC ICE

In the specification of TGIF, TGIF-TBC is not directly used as a TBC. Instead, we use TGIF-TBC : $\mathcal{K} \times \mathcal{M} \rightarrow \mathcal{M}$ as a building block (as a block cipher rather than TBC) to build another TBC : $\mathcal{K} \times \mathcal{T} \times \mathcal{M} \rightarrow \mathcal{M}$, where $\mathcal{K} = \{0, 1\}^k$ is the key space, $\mathcal{M} = \{0, 1\}^n$ is the message space, and $\mathcal{T} = \mathcal{N} \times \mathcal{D} \times \mathcal{B}$ is the tweak space. The tweak space \mathcal{T} consists of the nonce space $\mathcal{N} = \{0, 1\}^{nl}$, the

Algorithm $\text{ICEnc}_{L,V}^{D,B}(M)$

1. $S \leftarrow 2^D V \oplus M$
 2. $T_K \leftarrow \text{encode}(L, D, B)$
 3. $S \leftarrow E_{T_K}(S)$
 4. $C \leftarrow 2^D V \oplus S$
 5. **return** C
-

Figure 2.4: Definition of ICEnc , the core encryption routine of ICE. ICEnc is common to all two variants of ICE, ICE1 and ICE2 except the definition of encode . Note that ICE1 fixes $V = 0^n$, hence effectively $S \leftarrow M$ (line 1) and $C \leftarrow S$ (line 4). Variables L and V are assumed to be derived from the corresponding KDF taking (N, K) , as a pre-processing.

counter space $\mathcal{D} = \llbracket 2^d - 1 \rrbracket$, and the domain separation byte $\mathcal{B} = \llbracket 256 \rrbracket_0$ as described in Section 2.5.1. We call this TBC ICE (for Ideal-Cipher Encryption). There are two variants, ICE1 and ICE2.

Each variant consists of two main components, the key derivation function $\text{KDF} : \mathcal{K} \times \mathcal{N} \rightarrow \mathcal{L} \times \mathcal{V}$, and the “core” encryption function $\text{ICEnc} : (\mathcal{L} \times \mathcal{V}) \times (\mathcal{D} \times \mathcal{B}) \times \mathcal{M} \rightarrow \mathcal{M}$. Here, $\mathcal{L} = \mathcal{K} = \{0, 1\}^k$ and $\mathcal{V} = \mathcal{M} = \{0, 1\}^n$. The algorithm of ICEnc is shown in Figure 2.4 for all variants. In addition, there is a tweakable encode function $\text{encode} : \mathcal{L} \times \mathcal{D} \times \mathcal{B} \rightarrow \mathcal{K}$ inside ICEnc . For convenience, KDF for ICE1 may also be referred as KDF1. KDF2 is defined analogously.

An encryption of ICE is performed as follows. Given a tweak $T = (N, D, B) \in \mathcal{T}$, key $K \in \mathcal{K}$, and plaintext $M \in \mathcal{M}$, first, $\text{KDF}(N, K) \rightarrow (L, V)$ derives the nonce-dependent mask values (L, V) , and then ICEnc encrypts M as $\text{ICEnc}(L, V, D, B, M) \rightarrow C$, using the key of the internal E determined by $\text{encode}(L, D, B)$. Here, $\text{ICEnc}(L, V, D, B, *)$ is a permutation over \mathcal{M} for any (L, V, D, B) .

Each variant is defined as follows. The matrix G is defined at Section 2.5.3. For all variants, $k = 128$.

1. ICE1: $n = 128$, $nl = 128$, $d = 128$ and it uses TGIF-TBC as its building block E .
 - (a) $\text{KDF}(N, K) = (L, V)$ where $L = G(E_K(N))$, $V = 0^n$ using the matrix G .
 - (b) $\text{encode}(L, D, B) = 2^D L \oplus (0^{120} \parallel B)$.
2. ICE2: $n = 128$, $nl = 128$, $d = 128$ and it uses TGIF-TBC as its building block E .
 - (a) $\text{KDF}(N, K) = (L, V)$ where $L' = E_K(N)$, $V' = E_{K \oplus 1}(L')$, and $L = G(L')$ and $V = G(V')$.
 - (b) $\text{encode}(L, D, B) = 2^D L \oplus (0^{120} \parallel B)$.

Note that ICE1 and ICE2 are only different in the second mask V derived by their KDFs.

When ICE is working inside TGIF, the corresponding KDF is performed only once as an initialization. For ICE1 or ICE2, KDF involves one or two calls of E and matrix multiplications by G (see above). For each input block, ICE applies doubling to the derived mask values. Since doubling is a sequential operation, computing $\text{ICEnc}_{L,V}^{D+1,B}(M)$ after $\text{ICEnc}_{L,V}^{D,B}(M')$ is easy and does not need any additional memory.

2.5.3 State Update Function

Let G be an $n \times n$ binary matrix defined as an $n/8 \times n/8$ diagonal matrix of 8×8 binary sub-matrices:

$$G = \begin{pmatrix} G_s & 0 & 0 & \dots & 0 \\ 0 & G_s & 0 & \dots & 0 \\ \vdots & & & \ddots & \vdots \\ 0 & \dots & 0 & G_s & 0 \\ 0 & \dots & 0 & 0 & G_s \end{pmatrix},$$

where 0 here represents the 8×8 zero matrix, and G_s is an 8×8 binary matrix, defined as

$$G_s = \begin{pmatrix} 0 & 1 & 0 & 0 & 0 & 0 & 0 & 0 \\ 0 & 0 & 1 & 0 & 0 & 0 & 0 & 0 \\ 0 & 0 & 0 & 1 & 0 & 0 & 0 & 0 \\ 0 & 0 & 0 & 0 & 1 & 0 & 0 & 0 \\ 0 & 0 & 0 & 0 & 0 & 1 & 0 & 0 \\ 0 & 0 & 0 & 0 & 0 & 0 & 1 & 0 \\ 0 & 0 & 0 & 0 & 0 & 0 & 0 & 1 \\ 1 & 0 & 0 & 0 & 0 & 0 & 0 & 1 \end{pmatrix}.$$

Alternatively, let $X \in \{0, 1\}^n$, where n is a multiple of 8, then the matrix-vector multiplication $G \cdot X$ can be represented as

$$G \cdot X = (G_s \cdot X[0], G_s \cdot X[1], G_s \cdot X[2], \dots, G_s \cdot X[n/8 - 1]),$$

where

$$G_s \cdot X[i] = (X[i][1], X[i][2], X[i][3], X[i][4], X[i][5], X[i][6], X[i][7], X[i][7] \oplus X[i][0])$$

for all $i \in \llbracket n/8 \rrbracket_0$, such that $(X[0], \dots, X[n/8 - 1]) \stackrel{\delta}{\leftarrow} X$ and $(X[i][0], \dots, X[i][7]) \stackrel{1}{\leftarrow} X[i]$, for all $i \in \llbracket n/8 \rrbracket_0$.

The state update function $\rho : \{0, 1\}^n \times \{0, 1\}^n \rightarrow \{0, 1\}^n \times \{0, 1\}^n$ and its inverse $\rho^{-1} : \{0, 1\}^n \times \{0, 1\}^n \rightarrow \{0, 1\}^n \times \{0, 1\}^n$ are defined as

$$\rho(S, M) = (S', C),$$

where $C = M \oplus G(S)$ and $S' = S \oplus M$. Similarly,

$$\rho^{-1}(S, C) = (S', M),$$

where $M = C \oplus G(S)$ and $S' = S \oplus M$. We note that we abuse the notation by writing ρ^{-1} as this function is only the invert of ρ according to its second parameter. For any $(S, M) \in \{0, 1\}^n \times \{0, 1\}^n$, if $\rho(S, M) = (S', C)$ holds then $\rho^{-1}(S, C) = (S', M)$. Besides, we remark that $\rho(S, 0^n) = (S, G(S))$ holds.

2.5.4 TGIF-N nonce-based AE mode

The specification of TGIF-N is shown in Figure 2.5. Figures 2.6 and 2.7 show encryption of TGIF-N. For completeness, the definition of ρ is also included.

2.5.5 TGIF-M misuse-resistant AE mode

The specification of TGIF-M is shown in Figure 2.8. Figures 2.9 and 2.10 show encryption of TGIF-M. For completeness, the definition of ρ is also included.

<p>Algorithm TGIF-N.Enc_K(N, A, M)</p> <ol style="list-style-type: none"> 1. $(L, V) \leftarrow \text{KDF}(N, K)$ 2. $S \leftarrow 0^n$ 3. $(A[1], \dots, A[a]) \xleftarrow{r} A$ 4. $(M[1], \dots, M[m]) \xleftarrow{r} M$ 5. if $A[a] < n$ then $w_A \leftarrow 13$ else 12 6. if $M[m] < n$ then $w_M \leftarrow 11$ else 10 7. $A[a] \leftarrow \text{pad}_n(A[a])$ 8. for $i = 1$ to $a - 1$ 9. $(S, \eta) \leftarrow \rho(S, A[i])$ 10. $S \leftarrow \text{ICEnc}_{L,V}^{i,4}(S)$ 11. end for 12. $(S, \eta) \leftarrow \rho(S, A[a])$ 13. $S \leftarrow \text{ICEnc}_{L,V}^{\bar{a},w_A}(S)$ 14. for $i = 1$ to $m - 1$ 15. $(S, C[i]) \leftarrow \rho(S, M[i])$ 16. $S \leftarrow \text{ICEnc}_{L,V}^{a+i,2}(S)$ 17. end for 18. $M'[m] \leftarrow \text{pad}_n(M[m])$ 19. $(S, C'[m]) \leftarrow \rho(S, M'[m])$ 20. $S \leftarrow \text{ICEnc}_{L,V}^{a+m,w_M}(S)$ 21. $C[m] \leftarrow \text{lsb}_{ M[m] }(C'[m])$ 22. $(\eta, T) \leftarrow \rho(S, 0^n)$ 23. $C \leftarrow C[1] \parallel C[2] \parallel \dots \parallel C[m]$ 24. return (C, T) 	<p>Algorithm TGIF-N.Dec_K(N, A, C, T)</p> <ol style="list-style-type: none"> 1. $(L, V) \leftarrow \text{KDF}(N, K)$ 2. $S \leftarrow 0^n$ 3. $(A[1], \dots, A[a]) \xleftarrow{r} A$ 4. $(C[1], \dots, C[m]) \xleftarrow{r} C$ 5. if $A[a] < n$ then $w_A \leftarrow 13$ else 12 6. if $C[m] < n$ then $w_C \leftarrow 11$ else 10 7. $A[a] \leftarrow \text{pad}_n(A[a])$ 8. for $i = 1$ to $a - 1$ 9. $(S, \eta) \leftarrow \rho(S, A[i])$ 10. $S \leftarrow \text{ICEnc}_{L,V}^{i,4}(S)$ 11. end for 12. $(S, \eta) \leftarrow \rho(S, A[a])$ 13. $S \leftarrow \text{ICEnc}_{L,V}^{\bar{a},w_A}(S)$ 14. for $i = 1$ to $m - 1$ 15. $(S, M[i]) \leftarrow \rho^{-1}(S, C[i])$ 16. $S \leftarrow \text{ICEnc}_{L,V}^{a+i,2}(S)$ 17. end for 18. $\tilde{S} \leftarrow (0^{ C[m] } \parallel \text{msb}_{n- C[m] }(G(S)))$ 19. $C'[m] \leftarrow \text{pad}_n(C[m]) \oplus \tilde{S}$ 20. $(S, M'[m]) \leftarrow \rho^{-1}(S, C'[m])$ 21. $M[m] \leftarrow \text{lsb}_{ C[m] }(M'[m])$ 22. $S \leftarrow \text{ICEnc}_{L,V}^{a+m,w_C}(S)$ 23. $(\eta, T^*) \leftarrow \rho(S, 0^n)$ 24. $M \leftarrow M[1] \parallel M[2] \parallel \dots \parallel M[m]$ 25. if $T^* = T$ then return M else \perp
<p>Algorithm $\rho(S, M)$</p> <ol style="list-style-type: none"> 1. $C \leftarrow M \oplus G(S)$ 2. $S' \leftarrow S \oplus M$ 3. return (S', C) 	<p>Algorithm $\rho^{-1}(S, C)$</p> <ol style="list-style-type: none"> 1. $M \leftarrow C \oplus G(S)$ 2. $S' \leftarrow S \oplus M$ 3. return (S', M)

Figure 2.5: Encryption and decryption of TGIF-N. It uses TBC ICE consisting of KDF and ICEnc. Lines of [if (statement) then $X \leftarrow x$ else x'] are shorthand for [if (statement) then $X \leftarrow x$ else $X \leftarrow x'$]. The dummy variable η is always discarded. TGIF-N1 is used as a working example. For TGIF-N2 version, the values of the bit b_6 in the domain separation need to be set to 1, alongside with using the appropriate ICE and KDF variants.

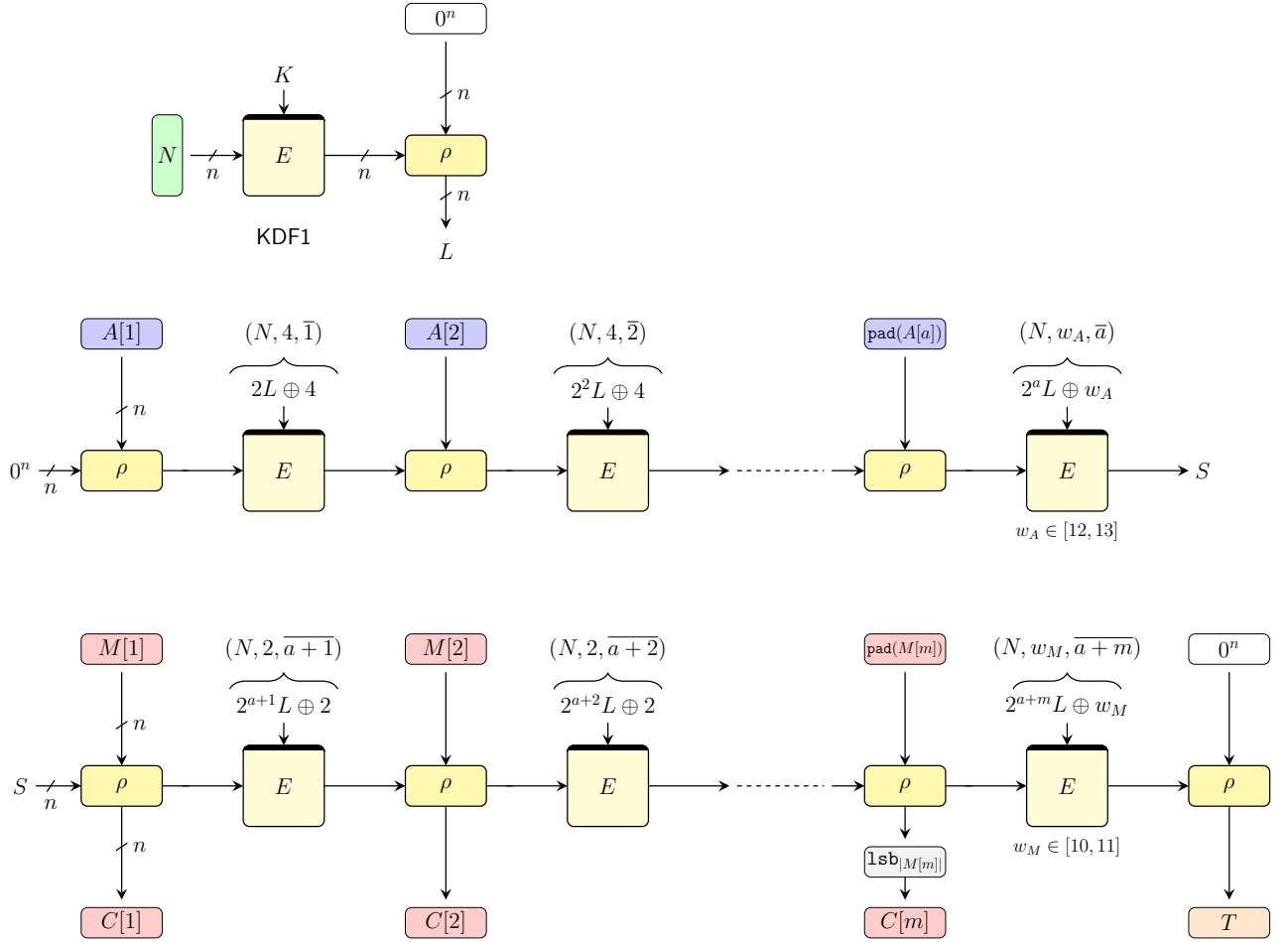

Figure 2.6: TGIF-N with ICE1 (TGIF-N1). (Top) Key derivation. (Middle) Processing of AD (Bottom) Encryption. The domain separation B being of 8 bits only, $\oplus B$ is to be interpreted as $\oplus 0^{120} || B$.

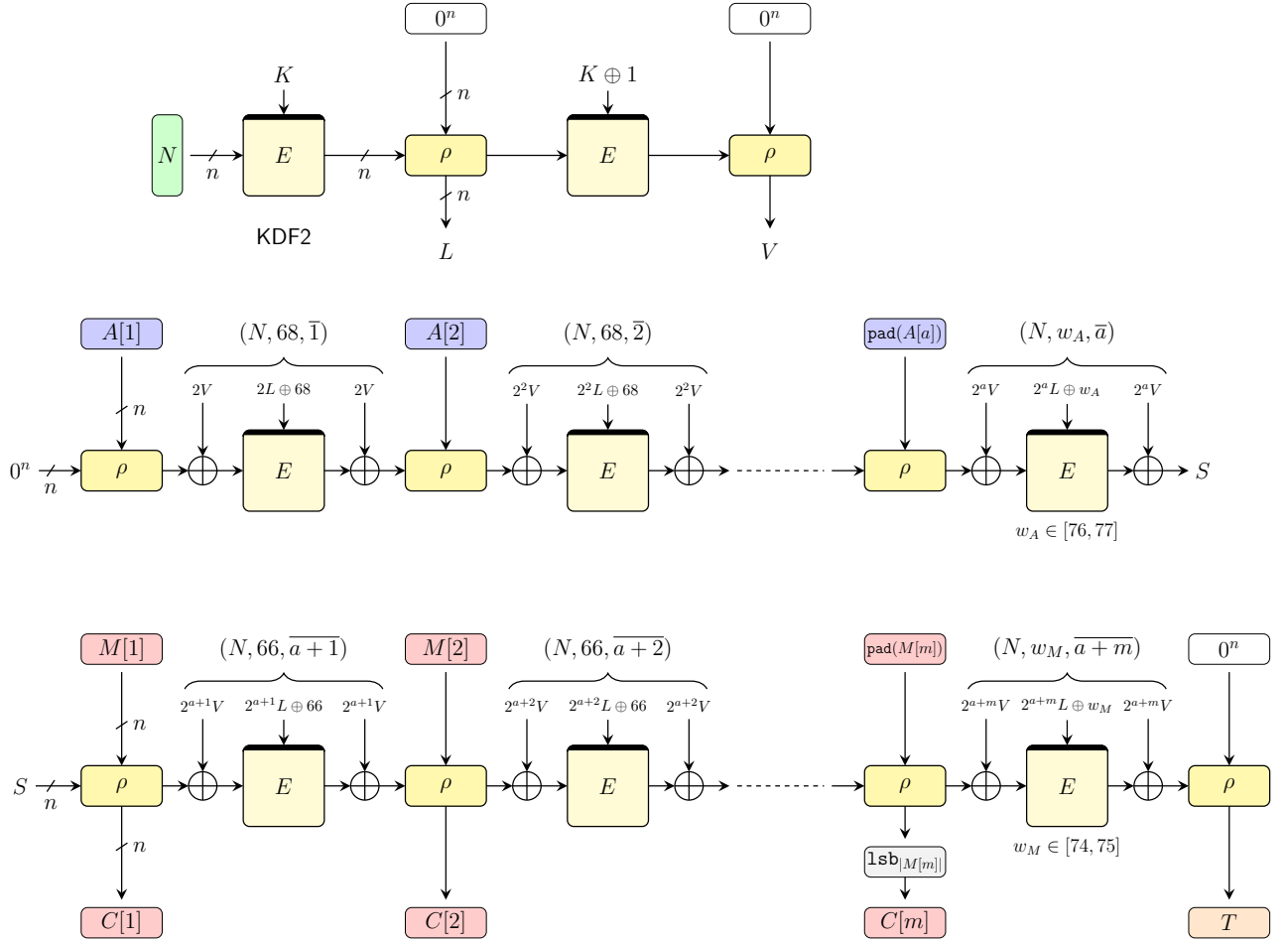

Figure 2.7: TGIF-N with ICE2 (TGIF-N2). (Top) Key derivation. (Middle) Processing of AD (Bottom) Encryption. The domain separation B being of 8 bits only, $\oplus B$ is to be interpreted as $\oplus 0^{120} \parallel B$.

Algorithm TGIF-M.Enc_K(N, A, M)

1. $(L, V) \leftarrow \text{KDF}(N, K)$
2. $S \leftarrow 0^n$
3. $(A[1], \dots, A[a]) \xleftarrow{r} A$
4. $(M[1], \dots, M[m]) \xleftarrow{r} M$
5. **if** $|A[a]| < n$ **then** $w_A \leftarrow 45$ **else** 44
6. **if** $|M[m]| < n$ **then** $w_M \leftarrow 47$ **else** 46
7. $A[a] \leftarrow \text{pad}_n(A[a])$
8. **for** $i = 1$ **to** $a - 1$
9. $(S, \eta) \leftarrow \rho(S, A[i])$
10. $S \leftarrow \text{ICEnc}_{L,V}^{i,36}(S)$
11. **end for**
12. $(S, \eta) \leftarrow \rho(S, A[a])$
13. $S \leftarrow \text{ICEnc}_{L,V}^{a,w_A}(S)$
14. **for** $i = 1$ **to** $m - 1$
15. $(S, \eta) \leftarrow \rho(S, M[i])$
16. $S \leftarrow \text{ICEnc}_{L,V}^{a+i,38}(S)$
17. **end for**
18. $M'[m] \leftarrow \text{pad}_n(M[m])$
19. $(S, \eta) \leftarrow \rho(S, M'[m])$
20. $S \leftarrow \text{ICEnc}_{L,V}^{a+m,w_M}(S)$
21. $(\eta, T) \leftarrow \rho(S, 0^n)$
22. **if** $M = \epsilon$ **then return** (ϵ, T)
23. $S \leftarrow T$
24. **for** $i = 1$ **to** $m - 1$
25. $S \leftarrow \text{ICEnc}_{L,V}^{i-1,34}(S)$
26. $(S, C[i]) \leftarrow \rho(S, M[i])$
27. **end for**
28. $S \leftarrow \text{ICEnc}_{L,V}^{\overline{m-1},34}(S)$
29. $(\eta, C'[m]) \leftarrow \rho(S, M'[m])$
30. $C[m] \leftarrow \text{lsb}_{|M[m]|}(C'[m])$
31. $C \leftarrow C[1] \parallel C[2] \parallel \dots \parallel C[m]$
32. **return** (C, T)

Algorithm TGIF-M.Dec_K(N, A, C, T)

1. $(L, V) \leftarrow \text{KDF}(N, K)$
2. **if** $C = \epsilon$ **then** $M \leftarrow \epsilon$
3. **else**
4. $S \leftarrow T$
5. $(C[1], \dots, C[m]) \xleftarrow{r} C$
6. $z \leftarrow |C[m]|$
7. $C[m] \leftarrow \text{pad}_n(C[m])$
8. **for** $i = 1$ **to** \overline{m}
9. $S \leftarrow \text{ICEnc}_{L,V}^{i-1,34}(S)$
10. $(S, M[i]) \leftarrow \rho^{-1}(S, C[i])$
11. **end for**
12. $M[m] \leftarrow \text{lsb}_z(M[m])$
13. $M \leftarrow M[1] \parallel \dots \parallel M[m]$
14. $S \leftarrow 0^n$
15. $(A[1], \dots, A[a]) \xleftarrow{r} A$
16. **if** $|A[a]| < n$ **then** $w_A \leftarrow 45$ **else** 44
17. **if** $|M[m]| < n$ **then** $w_M \leftarrow 47$ **else** 46
18. $A[a] \leftarrow \text{pad}_n(A[a])$
19. **for** $i = 1$ **to** $a - 1$
20. $(S, \eta) \leftarrow \rho(S, A[i])$
21. $S \leftarrow \text{ICEnc}_{L,V}^{i,36}(S)$
22. **end for**
23. $(S, \eta) \leftarrow \rho(S, A[a])$
24. $S \leftarrow \text{ICEnc}_{L,V}^{a,w_A}(S)$
25. **for** $i = 1$ **to** $m - 1$
26. $(S, \eta) \leftarrow \rho(S, M[i])$
27. $S \leftarrow \text{ICEnc}_{L,V}^{a+i,38}(S)$
28. **end for**
29. $M'[m] \leftarrow \text{pad}_n(M[m])$
30. $(S, \eta) \leftarrow \rho(S, M'[m])$
31. $S \leftarrow \text{ICEnc}_{L,V}^{a+m,w_M}(S)$
32. $(\eta, T^*) \leftarrow \rho(S, 0^n)$
33. **if** $T^* = T$ **then return** M **else** \perp

Algorithm $\rho(S, M)$

1. $C \leftarrow M \oplus G(S)$
2. $S' \leftarrow S \oplus M$
3. **return** (S', C)

Algorithm $\rho^{-1}(S, C)$

1. $M \leftarrow C \oplus G(S)$
 2. $S' \leftarrow S \oplus M$
 3. **return** (S', M)
-

Figure 2.8: TGIF-M using ICE. TGIF-M1 is used as a working example. For TGIF-M2 version, the values of the bit b_6 in the domain separation need to be set to 1, alongside with using the appropriate ICE and KDF variants.

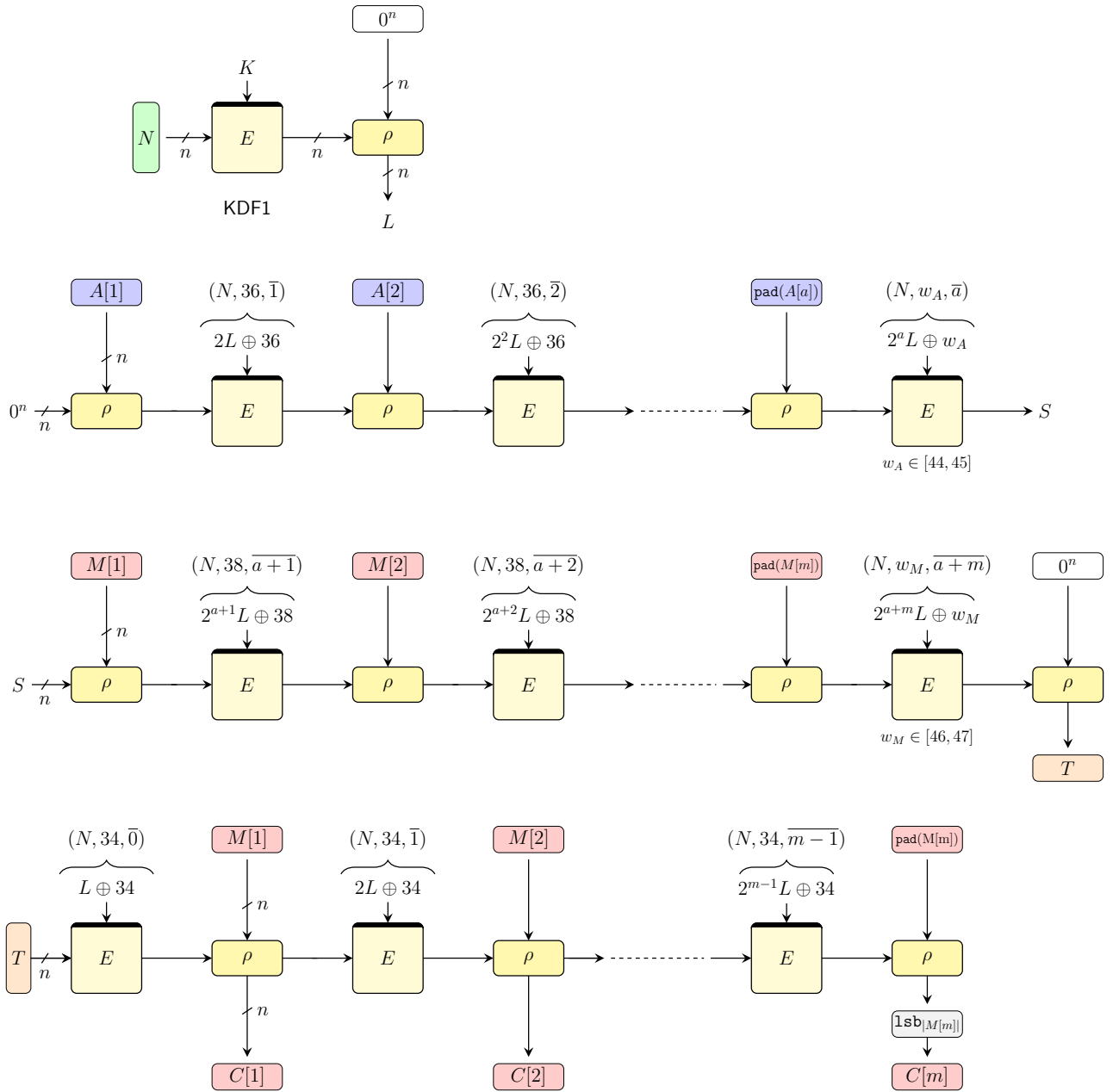

Figure 2.9: TGIF-M with ICE1 (TGIF-M1). (Top) Key derivation. (Middle-Top) Processing of AD (Middle-Bottom) Processing of M authentication (Bottom) Encryption. The domain separation B being of 8 bits only, $\oplus B$ is to be interpreted as $\oplus 0^{120}||B$.

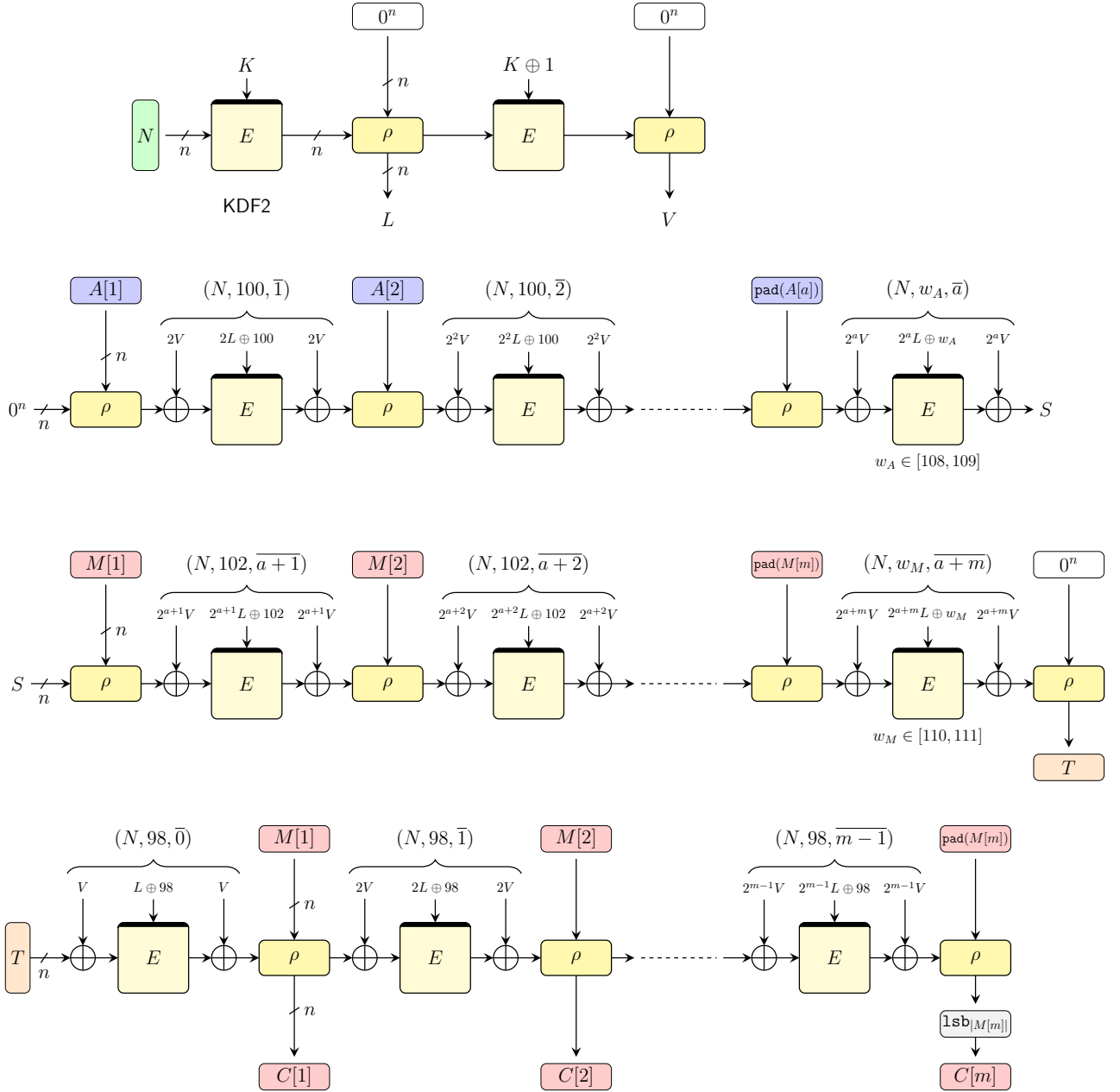

Figure 2.10: TGIF-M with ICE2 (TGIF-M2). (Top) Key derivation. (Middle-Top) Processing of AD (Middle-Bottom) Processing of M authentication (Bottom) Encryption. The domain separation B being of 8 bits only, $\oplus B$ is to be interpreted as $\oplus 0^{120}||B$.

Security Claims

Attack Models. We consider two models of adversaries: nonce-respecting (NR) and nonce-misusing (NM)¹. In the former model, nonce values in encryption queries (the tuples (N, A, M)) may be chosen by the adversary but they must be distinct. In the latter, nonce values in encryption queries can repeat. Basically, an NM adversary can arbitrarily repeat a nonce, hence even using the same nonce for all queries is possible. We can further specify NM by the distribution of a nonce, such as the maximum number of repetition of a nonce in the encryption queries. For both models, adversaries can use any nonce values in decryption queries (the tuples (N, A, C, T)): it can collide with a nonce in an encryption query or with other decryption queries.

Security Claims. Our security claims are summarized in Table 3.1. The variables in the table denote the required workload, in terms of online and offline query complexities (corresponding to data complexity and time complexity), of an adversary to break the cipher, in logarithm base 2. In more detail, an integer x in the table means an attack possibly breaks the scheme with online query complexity Q_{online} and offline query complexity Q_{offline} if $\max\{Q_{\text{online}}, Q_{\text{offline}}\} = 2^x$. For simplicity, small constant factors, which are determined from the concrete security bounds, are neglected in these tables. A more detailed analysis is given in Section 4.

We claim these numbers under the Ideal-Cipher Model (ICM), that is, the model that assumes TGIF-TBC is sampled uniformly over all the ciphers (see Section 4 for the definition). Intuitively, this corresponds to model that TGIF-TBC behaves ideally, though ICM cannot be instantiated (as a key of E is also a part of queries to ICM, and outputs must be random). ICM has been acknowledged as a meaningful security proof model, especially in the field of hash function constructions.

We can also obtain standard model proofs for TGIF, by assuming the intermediate TBC ICE as a keyed primitive called tweakable pseudorandom permutation (TPRP). The standard model proofs are actually a part of ICM proofs. Specifically, the security bounds under this standard model will appear in the hybrid argument of ICM proofs. A similar technique appeared in some permutation-based schemes [13, 32, 34], where the keyed primitive is a variant of Even-Mansour cipher. We warn that assuming ICE as TPRP does not imply its perfect security: there are generic attacks which work even if TGIF-TBC is an ideal-cipher. Therefore, the expected bit security levels are identical for both ICM and this standard model analyses. Therefore, Section 4 only presents the security bounds under ICM.

For TGIF-N1, Table 3.1 shows $n/2$ -bit security for both privacy and authenticity against NR adversary. For TGIF-N2, Table 3.1 shows full n -bit security for both privacy and authenticity against NR adversary.

For TGIF-M1, Table 3.1 shows $n/2$ -bit security for both privacy and authenticity against NR and NM adversaries. For TGIF-M2, Table 3.1 shows n -bit security for both privacy and authenticity

¹Also known as Nonce Repeating or Nonce Ignoring. We chose “Nonce Misuse” for notational convenience of using acronyms, NR for nonce-respecting and NM for nonce-misuse.

against NR adversary and in addition, $n/2$ -bit security for both privacy and authenticity against NM adversary. The $n/2$ -bit security assumes that the NM adversary has full control over the nonce, but in practice, the nonce repetition can happen accidentally, and it is conceivable that the nonce is repeated only a few times. As we present in Section 4, the security bounds of TGIF-M2 show the notable property of graceful security degradation with respect to the number of nonce repetition [35]. This property is similar to SCT, and if the number of nonce repetition is limited, the actual security bound is close to the full n -bit security.

Table 3.1: Security claims of TGIF. NR denotes Nonce-Respecting adversary and NM denotes Nonce-Misusing adversary.

Parameter	NR-Priv	NR-Auth	NM-Priv	NM-Auth
TGIF-N1	64	64	–	–
TGIF-N2	128	128	–	–
TGIF-M1	64	64	64	64
TGIF-M2	128	128	64 ~ 128	64 ~ 128

We claim these numbers under the Ideal-Cipher Model (ICM), that is, the model that assumes TGIF-TBC is sampled uniformly over all the ciphers (see Section 4 for the definition). Intuitively, this corresponds to model that TGIF-TBC behaves ideally, though ICM cannot be instantiated (as a key of E is also a part of queries to ICM, and outputs must be random). ICM has been acknowledged as a meaningful security proof model, especially in the field of hash function constructions.

For TGIF-N1, Table 3.1 shows $n/2$ -bit security for both privacy and authenticity against NR adversary. For TGIF-N2, Table 3.1 shows full n -bit security for both privacy and authenticity against NR adversary. For TGIF-M1, Table 3.1 shows $n/2$ -bit security for both privacy and authenticity against NR and NM adversaries. For TGIF-M2, Table 3.1 shows n -bit security for both privacy and authenticity against NR adversary and in addition, $n/2$ -bit security for both privacy and authenticity against NM adversary. The $n/2$ -bit security assumes that the NM adversary has full control over the nonce, but in practice, the nonce repetition can happen accidentally, and it is conceivable that the nonce is repeated only a few times. As we present in Section 4, the security bounds of TGIF-M2 show the notable property of graceful security degradation with respect to the number of nonce repetition [35]. This property is similar to SCT, and if the number of nonce repetition is limited, the actual security bound is close to the full n -bit security.

Key Recovery Security. For key recovery, the adversary needs to find the $k = 128$ -bit key used in KDF with 2^k offline queries (computations). See Table 3.2. Therefore, all members of TGIF have $k = 128$ -bit security against key recovery under the single-key setting.

Table 3.2: Security claims of TGIF against key recovery.

Parameter	Key Recovery
TGIF-N1	128
TGIF-N2	128
TGIF-M1	128
TGIF-M2	128

Security Analysis

4.1 Security of the mode

4.1.1 Security Notions

Security Notions for NAE. We consider the standard security notions for nonce-based AE [3, 4, 38]. Let Π denote an NAE scheme consisting of an encryption procedure $\Pi.\mathcal{E}_K$ and a decryption procedure $\Pi.\mathcal{D}_K$, for secret key K uniform over set \mathcal{K} (denoted as $K \stackrel{\$}{\leftarrow} \mathcal{K}$). For plaintext M with nonce N and associated data A , $\Pi.\mathcal{E}_K$ takes (N, A, M) and returns ciphertext C (typically $|C| = |M|$) and tag T . For decryption, $\Pi.\mathcal{D}_K$ takes (N, A, C, T) and returns a decrypted plaintext M if authentication check is successful, and otherwise an error symbol, \perp . We assume Π is based on the ideal block cipher $E : \mathcal{K} \times \mathcal{M} \rightarrow \mathcal{M}$, which is uniformly distributed over all block ciphers of key space \mathcal{K} and message space \mathcal{M} , and we allow the adversary to query E while attacking Π . Specifically, the adversary can query $Y \leftarrow E(K', X)$ for any $(K', X) \in \mathcal{K} \times \mathcal{M}$ or $X \leftarrow E^{-1}(K', Y)$ for any $(K', Y) \in \mathcal{K} \times \mathcal{M}$. We remark that K' here is a part of query and not the secret key $K \stackrel{\$}{\leftarrow} \mathcal{K}$. Such a query is called an offline query or a primitive query. In contrast, a query to $\Pi.\mathcal{E}_K$ or $\Pi.\mathcal{D}_K$ is called an online query or a construction query.

The privacy notion is the indistinguishability of encryption oracle $\Pi.\mathcal{E}_K$ from the random-bit oracle $\$$ which returns random $|M| + \tau$ bits for any query (N, A, M) , with access to the ideal cipher E for both worlds ($\$$ oracle and E oracle are independent). The adversary is assumed to be nonce-respecting. We define the privacy advantage as

$$\mathbf{Adv}_{\Pi}^{\text{priv}}(\mathcal{A}) \stackrel{\text{def}}{=} \Pr \left[K \stackrel{\$}{\leftarrow} \mathcal{K} : \mathcal{A}^{\Pi.\mathcal{E}_K(\cdot, \cdot, \cdot), (E, E^{-1})} \Rightarrow 1 \right] - \Pr \left[\mathcal{A}^{\$(\cdot, \cdot, \cdot), (E, E^{-1})} \Rightarrow 1 \right]$$

which measures the hardness of breaking the privacy notion for \mathcal{A} .

The authenticity notion is the probability of successful forgery via queries to $\Pi.\mathcal{E}_K$ and $\Pi.\mathcal{D}_K$ oracles. As in the case of the privacy notion, the adversary has access to E . We define the authenticity advantage as

$$\mathbf{Adv}_{\Pi}^{\text{auth}}(\mathcal{A}) \stackrel{\text{def}}{=} \Pr \left[K \stackrel{\$}{\leftarrow} \mathcal{K} : \mathcal{A}^{\Pi.\mathcal{E}_K(\cdot, \cdot, \cdot), \Pi.\mathcal{D}_K(\cdot, \cdot, \cdot), (E, E^{-1})} \text{ forges} \right],$$

where \mathcal{A} forges if it receives a value $M' \neq \perp$ from $\Pi.\mathcal{D}_K$. Here, to prevent trivial wins, if $(C, T) \leftarrow \Pi.\mathcal{E}_K(N, A, M)$ is obtained earlier, \mathcal{A} cannot query (N, A, C, T) to $\Pi.\mathcal{D}_K$. The adversary is assumed to be nonce-respecting for encryption queries.

Security Notions for MRAE. We adopt the security notions of MRAE following the same security definitions as above, with the exception that the adversary can now repeat nonces. We

write the corresponding privacy advantage as

$$\mathbf{Adv}_{\Pi}^{\text{nm-priv}}(\mathcal{A}) \stackrel{\text{def}}{=} \Pr \left[K \stackrel{\$}{\leftarrow} \mathcal{K} : \mathcal{A}^{\Pi.\mathcal{E}_K(\cdot, \cdot), (E, E^{-1})} \Rightarrow 1 \right] - \Pr \left[\mathcal{A}^{\mathcal{S}(\cdot, \cdot), (E, E^{-1})} \Rightarrow 1 \right],$$

and the authenticity advantage as

$$\mathbf{Adv}_{\Pi}^{\text{nm-auth}}(\mathcal{A}) \stackrel{\text{def}}{=} \Pr \left[K \stackrel{\$}{\leftarrow} \mathcal{K} : \mathcal{A}^{\Pi.\mathcal{E}_K(\cdot, \cdot), \Pi.\mathcal{D}_K(\cdot, \cdot), (E, E^{-1})} \text{ forges} \right].$$

We note that while adversaries can repeat nonces, we without loss of generality assume that they do not repeat the same query. See also [39] for reference.

4.1.2 Security of TGIF-N

For $A \in \{0, 1\}^*$, we say A has a AD blocks if $|A|_n = a$. Similarly for plaintext $M \in \{0, 1\}^*$ we say M has m message blocks if $|M|_n = m$. The same holds for the ciphertext C . For encryption query (N, A, M) or decryption query (N, A, C, T) of a AD blocks and m message blocks, the number of total TBC calls is at most $a + m$, which is called the number of *effective blocks* of a query.

Let \mathcal{A} be a nonce-respecting adversary against TGIF-N using q_c encryption (online/construction) queries and q_p offline/primitive queries with total number of effective blocks in encryption queries σ_{priv} . We have the following privacy bounds:

$$\begin{aligned} \mathbf{Adv}_{\text{TGIF-N1}}^{\text{priv}}(\mathcal{A}) &\leq \frac{9\sigma_{\text{priv}}^2 + 4\sigma_{\text{priv}} \cdot q_p}{2^n} + \frac{2q_p}{2^n}, \\ \mathbf{Adv}_{\text{TGIF-N2}}^{\text{priv}}(\mathcal{A}) &\leq \frac{9\sigma_{\text{priv}}^2 + 4\sigma_{\text{priv}} \cdot q_p}{2^{2n}} + \frac{2q_p}{2^n}. \end{aligned}$$

For authenticity bounds, let \mathcal{B} be a nonce-respecting adversary using q_c encryption queries and q_d decryption queries (both are online/construction queries), with total number of effective blocks for encryption and decryption queries σ_{auth} , and q_p offline/primitive queries. Also we define ℓ as the maximum effective block length of a plaintext among q_c encryption queries. Then we have

$$\begin{aligned} \mathbf{Adv}_{\text{TGIF-N1}}^{\text{auth}}(\mathcal{B}) &\leq \frac{9\sigma_{\text{auth}}^2 + 4\sigma_{\text{auth}} \cdot q_p}{2^n} + \frac{2q_p}{2^n} + \frac{2\ell q_d}{2^n} + \frac{2q_d}{2^\tau}, \\ \mathbf{Adv}_{\text{TGIF-N2}}^{\text{auth}}(\mathcal{B}) &\leq \frac{9\sigma_{\text{auth}}^2 + 4\sigma_{\text{auth}} \cdot q_p}{2^{2n}} + \frac{2q_p}{2^n} + \frac{2\ell q_d}{2^n} + \frac{2q_d}{2^\tau}. \end{aligned}$$

Note that tag length τ is set to n for all members of TGIF-N, however, if $1 \leq \tau < n$ (which is not a part of our submission), it still maintains n -bit privacy and τ -bit authenticity. While the term $\frac{2\ell q_d}{2^n}$ is present, this term is very likely not tight and can be improved to $\sigma_{\text{dec}}/2^n$ with total effective blocks in decryption queries σ_{dec} .

The security of TGIF-N crucially relies on the $n \times n$ matrix G defined over $\text{GF}(2)$. Let $G^{(i)}$ be an $n \times n$ matrix that is equal to G except the $(i+1)$ -st to n -th rows, which are set to all zero. Here, $G^{(0)}$ is the zero matrix and $G^{(n)} = G$, and for $X \in \{0, 1\}^n$, $G^{(i)}(X) = \mathbf{1sb}_i(G(X)) \parallel 0^{n-i}$ for all $i = 0, 8, 16, \dots, n$; note that all variables are byte strings, and $\mathbf{1sb}_i(X)$ is the leftmost $i/8$ bytes (Section 2). Let I denote the $n \times n$ identity matrix. We say G is sound if (1) G is regular and (2) $G^{(i)} + I$ is regular for all $i = 8, 16, \dots, n$. The above security bounds hold as long as G is sound. The proofs are similar to those for iCOFB [12]. We have verified the soundness of our G , for a range of n including $n = 64$ and $n = 128$, by a computer program.

4.1.3 Security of TGIF-M

For encryption query (N, A, M) or decryption query (N, A, C, T) of a AD blocks and m message blocks, the number of total TBC calls is at most $a + 2m$, which is called the number of *effective blocks* of a query.

Let \mathcal{A} be an adversary against TGIF-N using q_c encryption (online/construction) queries and q_p offline/primitive queries with total number of effective blocks in encryption queries σ_{priv} . In the NR case, we have the following privacy bounds:

$$\begin{aligned}\text{Adv}_{\text{TGIF-M1}}^{\text{priv}}(\mathcal{A}) &\leq \frac{9\sigma_{\text{priv}}^2 + 4\sigma_{\text{priv}} \cdot q_p}{2^n} + \frac{2q_p}{2^n}, \\ \text{Adv}_{\text{TGIF-M2}}^{\text{priv}}(\mathcal{A}) &\leq \frac{9\sigma_{\text{priv}}^2 + 4\sigma_{\text{priv}} \cdot q_p}{2^{2n}} + \frac{2q_p}{2^n}.\end{aligned}$$

In the NM case, we have the following privacy bounds:

$$\begin{aligned}\text{Adv}_{\text{TGIF-M1}}^{\text{nm-priv}}(\mathcal{A}) &\leq \frac{9\sigma_{\text{priv}}^2 + 4\sigma_{\text{priv}} \cdot q_p}{2^n} + \frac{2q_p}{2^n} + \frac{4r\sigma_{\text{priv}}}{2^n}, \\ \text{Adv}_{\text{TGIF-M2}}^{\text{nm-priv}}(\mathcal{A}) &\leq \frac{9\sigma_{\text{priv}}^2 + 4\sigma_{\text{priv}} \cdot q_p}{2^{2n}} + \frac{2q_p}{2^n} + \frac{4r\sigma_{\text{priv}}}{2^n}.\end{aligned}$$

Here, the adversary can repeat a nonce at most r times.

For authenticity bounds, let \mathcal{B} be an adversary using q_c encryption queries and q_d decryption queries (both are online/construction queries), with total number of effective blocks for encryption and decryption queries σ_{auth} , and q_p offline/primitive queries. Also we define ℓ as the maximum effective block length among all the encryption and decryption queries. Then in the NR case, we have

$$\begin{aligned}\text{Adv}_{\text{TGIF-M1}}^{\text{auth}}(\mathcal{B}) &\leq \frac{9\sigma_{\text{auth}}^2 + 4\sigma_{\text{auth}} \cdot q_p}{2^n} + \frac{2q_p}{2^n} + \frac{2\ell q_d}{2^n}, \\ \text{Adv}_{\text{TGIF-M2}}^{\text{auth}}(\mathcal{B}) &\leq \frac{9\sigma_{\text{auth}}^2 + 4\sigma_{\text{auth}} \cdot q_p}{2^{2n}} + \frac{2q_p}{2^n} + \frac{2\ell q_d}{2^n}.\end{aligned}$$

In the NM case, we have

$$\begin{aligned}\text{Adv}_{\text{TGIF-M1}}^{\text{nm-auth}}(\mathcal{B}) &\leq \frac{9\sigma_{\text{auth}}^2 + 4\sigma_{\text{auth}} \cdot q_p}{2^n} + \frac{2q_p}{2^n} + \frac{2r\ell q_d}{2^n}, \\ \text{Adv}_{\text{TGIF-M2}}^{\text{nm-auth}}(\mathcal{B}) &\leq \frac{9\sigma_{\text{auth}}^2 + 4\sigma_{\text{auth}} \cdot q_p}{2^{2n}} + \frac{2q_p}{2^n} + \frac{2r\ell q_d}{2^n}.\end{aligned}$$

In the above bounds, the adversary can repeat a nonce at most r times in encryption queries. The term $O(\frac{r\ell q_d}{2^n})$ is likely not tight and we expect that it can be improved to $O(r\sigma_{\text{dec}}/2^n)$ with total effective blocks in decryption queries σ_{dec} .

4.2 Security of TGIF-TBC

4.2.1 Differential and Linear Cryptanalysis

Evaluating the security of block cipher against differential cryptanalysis (DC) [7] and linear cryptanalysis (LC) [28] is the most common and fundamental procedure in the design and analysis phase. The lower bound for the number of active Sboxes involved in a differential or linear characteristic reflects the resistance of the cipher against these attacks to a certain degree.

In this work, we employ the automatic method based on the Boolean satisfiability problem (SAT) [40] to compute the lower bound for the number of active Sboxes in differential and linear trails for different numbers of rounds. The results are summarised in Table 4.1.

Table 4.1: Lower bounds for the number of active Sboxes.

DC/LC/RK	Round						
	1	2	3	4	5	6	7
DC	0	5	10	19	28	37	44
LC	0	5	10	17	27	37	43
RK	0	2	9	19	> 25	-	-

Differential cryptanalysis.

Since the Sbox of GIFT-64 has differential property $2^{-1.415}$, the number of active Sboxes only provides a rough estimation for the security of TGIF-TBC against differential cryptanalysis. To give a more accurate estimation, we revise the objective function of the automatic tool so that we can find differential trails with the optimal probability. We obtain a 4-step trail with differential probability $2^{-47.415}$. After fixing the input and output differences, we attempt to analyse the differential effect of the corresponding differential. In other words, we manage to enumerate the trails with the same input and output differences.

The search is conducted in a probability-first manner. Note that one differential characteristic is useful only if its probability is higher than 2^{1-n} for an n -bit block cipher. We exhaustively find trails with probability no less than 2^{-127} and take the summation of their probabilities. Note that the probability of the second-best trail is 2^{-108} and the number of trails with probabilities higher than 2^{-128} is 142. Thus, the probability of the 4-step differential equals $2^{-47.415}$, approximately. On average, it is expected that the differential probability will be lower than 2^{-127} when we have 12 steps. Therefore, we believe that 18-step TGIF-TBC is enough to bear differential cryptanalysis.

Linear cryptanalysis.

Note that for an n -bit block cipher, a trail with correlation c is valid only when c fulfils $c^2 > 2^{-n}$. The linear hull effect is related to multiples trails with the same input and output masks. The potential of the linear hull can be computed by the following theorem.

Theorem 1 ([14]). *The square of a correlation (or correlation contribution) is called correlation potential. The average correlation potential between an input and output selection pattern is the sum of the correlation potentials of all linear trails between the input and output selection patterns.*

Now, we replace the objection function focusing on the number of active Sboxes with the one centred on the correlation of the linear approximation and obtain a 4-step trail with correlation 2^{-21} . To study the linear hull effect, we fix the input and output masks and exhaustively search for trails with the correlation more significant than 2^{-64} . The results indicate that the correlation of the second-best trail is 2^{-51} , and the number of trails with $c > 2^{-64}$ is 4606. Thus, for TGIF-TBC, the 4-step linear hull has correlation potential 2^{-42} , approximately. On average, it is expected to require 13-step to make the correlation potential strictly lower than 2^{-128} . Therefore, we believe that 18-step TGIF-TBC is sufficient to provide resistance against linear cryptanalysis.

Related-key differential cryptanalysis.

The lower bound for the number of active Sboxes in a related-key (RK) differential characteristic can be found in Table 4.1. For 2-step and 3-step encryptions, the lower bounds for the differential probability are 2^{-4} and $2^{-22.83}$, respectively. Since the programs for the search of probability

bounds for more than 3-step do not finish in a reasonable time, we use the average value to estimate the security bound under related-key setting. Note that the 3-round differential trail with optimal probability has 12 active Sboxes, the average probability for one Sbox is $2^{-1.9}$. To ensure the probability to be lower than 2^{-128} , we need 68 active Sboxes. Since the number of active Sboxes for 5-step encryption is no less than 26, it is expected that 14-step of encryption will have more than 68 active Sboxes on average. Thus, we believe that 18-step TGIF-TBC is enough to withstand related-key differential cryptanalysis.

4.2.2 Integral Cryptanalysis

We use the automatic tool based on MILP method [44] to trace the propagation of the bit-based division property [41, 42] of TGIF-TBC. To obtain the longest integral distinguisher, we set only one bit in the plaintext as constant, and the others are set as active. The maximum number of steps that the integral distinguisher exists is six. When the unique constant bit is located at the left branch of the input, all the 64 bits in the right branch satisfy zero-sum property after six steps of encryption. In other words, we find 64 6-step integral distinguishers with data complexity being 2^{127} chosen plaintexts

$$(A^i C A^{64-i-1}, A^{64}) \rightarrow (U^{64}, B^{64}), 0 \leq i \leq 63,$$

where ‘ A^i ’, ‘ B^i ’, and ‘ U^i ’ respectively stands for i consecutive active, zero-sum, and unknown bits, and ‘ C ’ represents a constant bit.

Then, we manage to reduce the data requirement of the 6-step distinguisher. We fix the first c bits as constant and gradually increase the value of c until there is no zero-sum bit after six steps of encryption. Finally, we obtain a 6-step integral distinguisher with data requirement being 2^{116} ,

$$(C^{12} A^{52}, A^{64}) \rightarrow (U^{64}, U^4 B U^3 B U^6 B U^{48}).$$

Note that GIFT-64 achieves full diffusion in three rounds. If the 6-step distinguisher is utilised in a key-recovery attack and the attacker wants to use at least one zero-sum bit to recover the information about the subkeys, appending two steps after the distinguisher will make the full tweakey state to be involved in the key-guessing phase. Thus, we claim that full steps of TGIF-TBC are enough to resist the integral cryptanalysis.

4.2.3 Impossible Differential Cryptanalysis

Impossible differential cryptanalysis [6, 24] exploits the differential which never occurs. In the key recovery attack, the attacker puts the impossible differential distinguisher $(\Delta_{in}, \Delta_{out})$ in the middle of the objective cipher and appends several rounds before and after it. Given a pair of plaintexts with input difference ΔP and output difference ΔC , the adversary guesses the subkeys involved in the appended rounds and partially encrypts/decrypts the pair to obtain the intermediate differences at the head and tail of the distinguisher. The subkeys that result in the impossible differential are rejected.

We modify the automatic tool based on SAT method [40] to search for impossible differentials with fixed input and output differences. The internal state is seen as 32 nibbles. We exhaustively test the combinations of input and output differences satisfying the following conditions:

- the input difference has one active nibble;
- the output difference has one active nibble.

The number of input/output difference satisfying the first/second condition is $32 \times 15 = 480$. Thus, we evaluate $480 \times 480 = 230400$ pairs of input and output differences.

The search results indicate that all the 230400 differentials constitute 3-step impossible differential, while all of these differentials become possible ones after four steps of encryption. Since the length of the impossible differential is very short, we think full steps of TGIF-TBC are sufficient to resist the impossible differential attack.

4.2.4 Zero-correlation Linear Cryptanalysis

Zero-correlation linear cryptanalysis [8] relies on linear approximations with correlation zero. We also use the automatic tool based on SAT method [40] to realise the search of zero-correlation distinguisher with fixed input and output masks. The internal state is regarded as 32 nibbles. We check all the combinations of input and output masks with only one active nibble. The optimal distinguisher in this setting achieves four steps, and the number of zero-correlation linear approximations we found is 57580. All the 230400 combinations correspond to linear approximations with non-zero correlation after five steps of encryption. Note that the length of the zero-correlation linear approximation is very short, and we believe that full steps of TGIF-TBC are sufficient to withstand this kind of attack.

Features

The primary goal of TGIF is to provide a lightweight, yet highly-secure, highly-efficient AE based on a new TBC named TGIF-TBC. TGIF has a number of desirable features. Below we detail some representative ones:

- **Performance of TBC.** TGIF-TBC is an extremely efficient TBC, both in terms of area and throughput, on a broad range of devices, from very constrained hardware to high-end software platforms. It has the very interesting property that it can either be seen as a classical SPN cipher (which makes it very easy to analyse its security and derive bounds for differential/linear cryptanalysis) or as a bitslice-oriented cipher that allows very efficient constant time bitslice implementations, even without parallel primitive calls. Its most efficient implementation is straightforward and can be easily adapted to various architectures and to enable area/throughput trade-offs. TGIF-TBC is even more efficient than the 128-bit version of GIFT (one of the most lightweight block cipher to date), while providing stronger security guarantees. It is as of today one of the 128-bit primitive that uses the smallest number of basic boolean operations. Moreover, it has the special property that its key schedule naturally brings back the key state to its original input value at the end of the cipher computation, which will allow the designer to save area in the mode.

Table 5.1: Estimations for the hardware area and number of cycles (throughput) of round-based implementations of GIFT, SKINNY, SIMON and our new cipher TGIF-TBC

	Area (GE)	Cycles
TGIF-TBC	1592	72
TGIF-TBC	2096	36
TGIF-TBC	3105	18
GIFT-128	1997	41
SKINNY-128-128	2104	40
SIMON 128/128	2064	69

- **Performance of Mode.** TGIF-N mode is efficient: it encrypts an n -bit block by just one call of n -bit-block primitive. Besides, it is smaller than ΘCB3 in that it does not need an additional state beyond the internal TBC and it requires a smaller TBC (smaller tweak). Although TGIF is serial in nature, *i.e.*, not parallelizable, it was shown during the CAESAR competition that parallelizability does not lead to significant performance gains in hardware performance [16, 23, 27]. Moreover, parallelizability is not considered crucial in lightweight applications, so it is a small price for a simple, small and fast design.
- **Security of TBC.** The dual nature of TGIF-TBC (SPN/bitslice) allows us to study TGIF-TBC as a classical SPN cipher, with enough structure so that automated tools (SAT, MILP, etc.) can easily obtain bounds on the number of active boxes in a differential or linear attack. For

Table 5.2: Total number of operations and theoretical performance of GIFT and various lightweight block ciphers. N denotes a NOR gate, A denotes a AND gate, X denotes a XOR gate.

Cipher	nb. of rds	gate cost (per bit per round)			nb. of op. w/o key sch.	nb. of op. w/ key sch.	round-based impl. area
		int. cipher	key sch.	total			
TGIF-TBC	72	0.5 N 0.87 X	0.5 X	0.5 N 1.37 X	1.37×72 = 99	1.87×72 = 135	$0.5 + 2.67 \times 1.37$ = 4.17
GIFT -128-128	40	1 N 2 X		1 N 2 X	3.0×40 = 120	3.0×40 = 120	$1 + 2.67 \times 2$ = 6.34
SKINNY -128-128	40	1 N 2.25 X		1 N 2.25 X	3.25×40 = 130	3.25×40 = 130	$1 + 2.67 \times 2.25$ = 7.01
SIMON -128/128	68	0.5 A 1.5 X	1 X	0.5 A 2.5 X	2×68 = 136	3×68 = 204	$0.67 + 2.67 \times 2.5$ = 7.34
AES -128	10	4.25 A 16 X	1.06 A 3.5 X	5.31 A 19.5 X	20.25×10 = 202.5	24.81×10 = 248.1	$7.06 + 2.67 \times 19.5$ = 59.12

example, we can show that the best differential path for 4 steps of TGIF-TBC has probability $2^{-47.415}$.

- **Security proofs for the mode.** Both TGIF-N and TGIF-M have provable security in the Ideal-Cipher Model (ICM), where TGIF-TBC is modeled as the ideal-cipher. This is very important for high security confidence of TGIF and allows us to rely on the security of TGIF to that of TGIF-TBC. As mentioned above, TGIF-TBC allows an extensive security analysis on various metrics by using automated tools. Our provable security results are relying on the model where TGIF-TBC behaves as the ideal-cipher. It tells us that unless we find a structural weakness of TGIF-TBC, TGIF will be secure, as in the same way of reasoning for (public) permutation-based schemes, such as Sponge.
- **Beyond-birthday-bound security (TGIF-N2 and TGIF-M2).** The security bounds of TGIF-N2 shown in Section 4 are comparable to the state-of-the-art TBC modes of operation, namely Θ CB3 for NAE and SCT for MRAE. In particular, TGIF-N2 and TGIF-M2 (under NR adversary) achieve beyond-birthday-bound (BBB) security with respect to the block length. This level of security is much stronger than the up-to-birthday-bound, $n/2$ -bit security achieved by conventional block cipher modes using n -bit block ciphers, *e.g.* GCM. We note that the above comparison ignores the fact that Θ CB3 and SCT use a dedicated TBC while ours use an (ideal) block cipher. This is simply because of the lack of BBB-secure NAE/MRAE schemes based on the ideal-cipher: combining known ICM-to-TBC results [21, 31, 43] and TBC-based modes would be possible, however, the performance will be quite poor unless the tweak-dependent key derivation is very carefully considered, which is exactly the point we carefully elaborated in our design.
- **Misuse resistance.** TGIF-M is an MRAE mode which is secure against misuse (repeat) of nonces in encryption queries. More formally, it provides the best-possible security against nonce repeat in that ciphertexts do not give any information as long as the uniqueness of the input tuple (N, A, M) is maintained. In contrast to this, popular nonce-based AE modes are often vulnerable against nonce repeat, even one repetition can be significant. For example, the famous nonce repeat attack against GCM [17, 22] reveals its authentication key.
- **Small messages.** The variants of TGIF are efficient for small-message scenario. For example, TGIF-N1 and TGIF-N2 require 3 and 4 TBC calls, respectively, for processing 1 block of AD and 1 block of message.
- **Simplicity/Small footprint.** TGIF has a quite small footprint. Especially for TGIF-N, we essentially need what is needed to implement the TBC TGIF-TBC itself, and one-block mask exclusively used by TGIF-N2 and TGIF-M2. We remark that this becomes possible thanks

to the permutation-based structure of TGIF-TBC’s tweakable schedule, which allows to share the state registers used for storing input variable and for deriving round-key values. Thus, this feature is specific to our use of TGIF-TBC, though one can expect a similar effect with TBC using a simple tweak(ey) schedule. We do not need the inverse circuit for TGIF-TBC which was needed for ΘCB3 . A comparison in Section 6 (Table 6.1) shows that TGIF-N is quite small and especially efficient in terms of a combined metric of size and speed, compared with other schemes.

TGIF-M also has a small footprint due to the shared structure with TGIF-N.

- **Flexibility.** TGIF has a large flexibility. Generally, it is defined as a generic mode for TBCs, and the security proofs under ICM contribute to a high confidence of the scheme when combined with a secure TBC under related-tweakable model. In fact, all mode versions of TGIF (and some others) are used in the Remus design [?] with a different underlying TBC.
- **Side channels.** TGIF does not inherently guarantee security against Side Channel Analysis and Fault Attacks. However, standard countermeasures are easily adaptable for TGIF, *e.g.* Fresh Rekeying [30], Masking [33], etc. Moreover, powerful fault attacks that require a small number of faults and pairs of faulty and non-faulty ciphertexts, such as DFA, are not applicable to TGIF-N without violating the security model, *i.e.*, misusing the nonce or releasing unverified plaintexts. We plan to study the applicability/cost of such countermeasures, in addition to newly proposed countermeasures suited specifically for TGIF in subsequent works.

Design Rationale

TGIF is designed with the following goals in mind:

1. Have a small-footprint and efficient TBC internal primitive, while providing strong security guarantees against state-of-the-art attacks.
2. Have a very small area compared to other TBC/BC based AEAD modes, while providing security proofs in the well-established ideal-cipher model.

6.1 TGIF-TBC Design

Our cipher TGIF-TBC can be seen as an improvement over GIFT, while enabling tweakable capability. This work was initiated by the new observation of a special structure in GIFT cipher, that can greatly improve its performance in software. Namely, instead of performing the normal bit permutation of GIFT (efficient on hardware, but can be slow on software), one can instead use an alternative representation during 4 rounds, that will eventually have a completely equivalent effect as the normal 4 rounds of GIFT. This new representation, bitslice in essence, only uses very simple rotations which are easy to perform in software.

In other words, we retain all the benefits from the structure and the analysis of GIFT (ability to easily get a number of active Sboxes for differential and linear cryptanalysis, etc.), while having a very efficient alternative bitslice representation of it. TGIF-TBC can be seen as a link between SPN ciphers and AND-Rotation-XOR ciphers.

We note that this type of special bitslice representation of GIFT is simple for its 64-bit version, but not for its 128-bit one. This is the reason why we chose to use GIFT-64 as basic building block (and a Misty structure to propose a 128-bit cipher). Besides, this representation goes back to identity after 4 rounds of GIFT, which is why we used 4 rounds inside the GIFT-64 black-box. Overall, our cipher is notably more efficient than GIFT-128, one of the very lightest cipher recently published, while actually ensuring a higher number of active Sboxes per Sbox computed. The analysis is also simpler for related-key attacks, which allows use to enable the crucial tweak capability, that leads to very efficient and lightweight authenticated encryption modes, such as Remus.

The tweakable schedule of TGIF-TBC has been chosen so as to minimize the number of XORs, while proposing acceptable diffusion in the tweakable state. It is also very simple and efficient to compute this tweakable schedule on the fly. Besides, we forced the special feature that the tweakable schedule naturally makes the tweakable state to come back to its initial value at the end of the cipher computation. This has two benefits in practice. First, for decryption the tweakable passed as input is the tweakable state to start the decryption from (no need to compute the entire tweakable schedule for all rounds in order to obtain the starting decryption tweakable state). Secondly, in serial modes like Remus, saving memory is crucial for lightweight performances. Since TGIF-TBC will receive some special counter-like value to its tweakable input, this key schedule feature will allow to avoid

allocating extra memory to compute the cipher: the counter register can directly be used for free as tweakable state.

6.2 Mode Design

Rationale of NAE Mode. By seeing TGIF-N as a mode of TBC (ICE), TGIF-N has a similar structure as a mode called iCOFB, which appeared in the full version of CHES 2017 paper [12]. Because it was introduced to show the feasibility of the main proposal of [10], block cipher mode COFB, it does not work as a full-fledged AE using conventional TBCs. Therefore, starting from iCOFB, we apply numerous changes for improving efficiency while achieving high security. As a result, TGIF-N becomes a much more advanced, sophisticated NAE mode based on a TBC. Assuming ICE is an ideally secure TBC, the security bound of TGIF-N is essentially equivalent to Θ CB3, having full n -bit security. The remaining problem is how to efficiently instantiate TBC. We could use a dedicated TBC, or a conventional block cipher mode (such as XEX [37]), however, they have certain limitations on security and efficiency. To overcome such limitations, we choose to use a block cipher with tweak-dependent key/mask derivation. This approach, initiated by Mennink [31], enables the performance that cannot be achieved by the previous approaches, at the expense of the ideal-cipher model for security. Specifically, the TBC ICE has 2 variants, ICE1 and ICE2, that can be seen as a variant of XHX [21]. Each variant has its own security level, namely, ICE1 has $n/2$ -bit security and ICE2 has n -bit security. They have different computation cost for key/mask derivations and have different state sizes. Given the n -bit security of *outer* TBC-based mode, the standard hybrid argument shows that the security of TGIF-N is effectively determined by the security of the internal ICE.

Rationale of MRAE Mode. TGIF-M is designed as an MRAE mode following the structure of SIV [39] and SCT [35]. TGIF-M reuses the components of TGIF-N as much as possible to inherit its implementation advantages and the security. In fact, this brings us several advantages (not only for implementation aspects) over SIV/SCT. TGIF-M needs an equivalent number of primitive calls as SCT. The difference is in the primitive: TGIF-M uses an n -bit block cipher while SCT uses an n -bit-block dedicated TBC. Moreover, TGIF-M has a smaller state than SCT because of single-state encryption part taken from TGIF-N (SCT employs a variant of counter mode). Similarly to TGIF-N, the provable security of TGIF-M is effectively determined by the internal ICE. For TGIF-M2, thanks to n -bit security of ICE2, its security is equivalent to SCT: the security depends on the maximum number of repetition of a nonce in encryption (r), and if $r = 1$ (*i.e.*, NR adversary), we have the full n -bit security. Security will gradually decrease as r increases, also known as “graceful degradation”, and even if r equals to the number of encryption queries, implying nonces are fixed, we maintain the birthday-bound, $n/2$ -bit security. For TGIF-M1, the security is $n/2$ bits for both NR and NM adversaries due to the $n/2$ -bit security of ICE1.

ZAE [20] is another TBC-based MRAE. Although it is faster than SCT, the state size is much larger than SCT and TGIF-M.

Efficiency Comparison. In Table 6.1, we compare TGIF-N to Θ CB3, COFB, Beetle and Ascon, where state size is the minimum number of bits that the mode has to maintain during its operation, and rate is the ratio of input data length divided by the total output length of the primitive needed to process that input. Θ CB3 is a well-studied TBC-based AEAD mode. COFB is a BC-based lightweight AEAD mode. Beetle is a Sponge-based AEAD mode, but it holds a lot of resemblance to TGIF-N. The comparison follows the following guidelines, while trying to be fair in comparing designs that follow completely different approaches:

1. $k = 128$ for all the designs.

Table 6.1: Features of TGIF-N members compared to Θ CB3 and other lightweight AEAD algorithms: λ is the bit security level of a mode. Here, (n, k) -BC is a block cipher of n -bit block and k -bit key, (n, t, k) -TBC is a TBC of n -bit block and k -bit key and t -bit tweak, and n -Perm is an n -bit cryptographic permutation.

Scheme	Number of Primitive Calls	Primitive	Security (λ)	State Size (S)	Rate (R)	S/R	Inverse Free
TGIF-N1	$\lceil \frac{ A }{n} \rceil + \lceil \frac{ M }{n} \rceil + 1$	(n, k) -BC, $n = k$	$n/2$	$n + k = 4\lambda^\dagger$	1	4λ	Yes
TGIF-N2	$\lceil \frac{ A }{n} \rceil + \lceil \frac{ M }{n} \rceil + 2$	(n, k) -BC, $n = k$	n	$2n + k = 3\lambda$	1	3λ	Yes
COFB [11]	$\lceil \frac{ A }{n} \rceil + \lceil \frac{ M }{n} \rceil + 1$	(n, k) -BC, $n = k$	$n/2 - \log_2 n/2$	$1.5n + k = 5.4\lambda^\ddagger$	1	5.4λ	Yes
Θ CB3 [26]	$\lceil \frac{ A }{n} \rceil + \lceil \frac{ M }{n} \rceil + 1$	$(n, 1.5n, k)$ -TBC [‡] , $n = k$	n	$2n + 2.5k = 4.5\lambda$	1	4.5λ	No
Beetle [9]	$\lceil \frac{ A }{n} \rceil + \lceil \frac{ M }{n} \rceil + 2$	$2n$ -Perm, $n = k$	$n - \log_2 n$	$2n = 2.12\lambda$	1/2	4.24λ	Yes
Ascon-128 [15]	$\lceil \frac{ A }{n} \rceil + \lceil \frac{ M }{n} \rceil + 1$	$5n$ -Perm, $n = k/2$	$n/2$	$7n = 3.5\lambda$	1/5	17.5λ	Yes
Ascon-128a [15]	$\lceil \frac{ A }{n} \rceil + \lceil \frac{ M }{n} \rceil + 1$	$2.5n$ -Perm, $n = k$	n	$3.5n = 3.5\lambda$	1/2.5	8.75λ	Yes
SpongeAE ^b [5]	$\lceil \frac{ A }{n} \rceil + \lceil \frac{ M }{n} \rceil + 1$	$3n$ -Perm, $n = k$	n	$3n = 3\lambda$	1/3	9λ	Yes

[†] Can possibly be enhanced to 3λ with a different KDF and block cipher with $2k$ -bit key;

[‡] Can possibly be enhanced to about 4λ with a $2n$ -bit block cipher;

[‡] $1.5n$ -bit tweak for n -bit nonce and $0.5n$ -bit counter;

^b Duplex construction with n -bit rate, $2n$ -bit capacity.

- n is the input block size (in bits) for each primitive call.
- λ is the security level of the design.
- For BC/TBC based designs, the key is considered to be stored inside the design, but we also consider that the encryption and decryption keys are interchangeable, *i.e.*, the encryption key can be derived from the decryption key and vice versa. Hence, there is no need to store the master key in additional storage. The same applies for the nonce.
- For Sponge and Sponge-like designs, if the key/nonce are used only during initialization, then they are counted as part of the state and do not need extra storage. However, in designs like Ascon, where the key is used again during finalization, we assume the key storage is part of the state, as the key should be supplied only once as an input.

Our comparative analysis of these modes show that TGIF-N achieves its goals, as TGIF-N1 has $2n$ state, which is smaller than COFB and equal to Beetle. TGIF-N1 and COFB both have birthday security, *i.e.*, $n/2$. Beetle achieves higher security, at the expense of using a $2n$ -bit permutation. Our analysis also shows that among the considered AEAD modes, TGIF-N2 achieves the lowest S/R ratio, with a state size of $3n$ but only an n -bit permutation.

Similar comparison is shown in Table 6.2 for Misuse-Resistant BC- and TBC-based AEAD modes. It shows that TGIF-M2 particularly is very efficient.

6.2.1 Hardware Implementations

The goal of the design of TGIF is to have a very small area overhead over the underlying TBC, specially for the round-based implementations. In order to achieve this goal, we set two requirements:

- There should be no extra Flip-Flops over what is already required by the TBC, since Flip-Flops are very costly ($4 \sim 7$ GEs per Flip-Flop).
- The number of possible inputs to each Flip-Flop and outputs of the circuits have to be minimized. This is in order to reduce the number of multiplexers required, which is usually one of the cause of efficiency reduction between the specification and implementation.

Table 6.2: Features of TGIF-M members compared to other MRAE modes : λ is the bit security level of a mode. Here, (n, k) -BC is a block cipher of n -bit block and k -bit key, (n, t, k) -TBC is a TBC of n -bit block and k -bit key and t -bit tweak. Security is for Nonce-respecting adversary.

Scheme	Number of Primitive Calls	Primitive	Security (λ)	State Size (S)	Rate (R)	S/R	Inverse Free
TGIF-M1	$\lceil \frac{ A + M }{n} \rceil + \lceil \frac{ M }{n} \rceil + 1$	(n, k) -BC, $n = k$	$n/2$	$2n = 4\lambda$	$1/2$	8λ	Yes
TGIF-M2	$\lceil \frac{ A + M }{n} \rceil + \lceil \frac{ M }{n} \rceil + 2$	(n, k) -BC, $n = k$	n	$3n = 3\lambda$	$1/2$	6λ	Yes
SCT [†] [36]	$\lceil \frac{ A + M }{n} \rceil + \lceil \frac{ M }{n} \rceil + 1$	(n, n, k) -TBC, $n = k$	n	$4n = 4\lambda$	$1/2$	8λ	Yes
SUNDAE [1]	$\lceil \frac{ A + M }{n} \rceil + \lceil \frac{ M }{n} \rceil + 1$	(n, k) -BC, $n = k$	$n/2$	$2n = 4\lambda$	$1/2$	8λ	Yes
ZAE [#] [20]	$\lceil \frac{ A + M }{2n} \rceil + \lceil \frac{ M }{n} \rceil + 6$	(n, n, k) -TBC, $n = k$	n	$7n = 7\lambda$	$1/2$	14λ	Yes

[†] Tag is n bits;

[#] Tag is $2n$ bits;

In this section, we describe various design choices that help achieve these two goals.

General Architecture and Hardware Estimates. The mode was designed with the architecture in Figure 6.1 in mind, where only a full-width state-register is used, carrying the TBC state and tweak values, and every cycle, it is either kept without change, updated with the TBC round output (which includes a single round of the key scheduling algorithm) or the output of a simple linear transformation, which consists of ρ/ρ^{-1} and the block counter.

Hardware Cost of TGIF-N1. The overhead of TGIF-N1 is mostly due to the doubling (3 XORs) and ρ operations (68 XORs, assuming the input/output bus has width of 32 bits). Moreover, we need 2 128-bit multiplexers to select the input to the tweakkey out of four positive values: K , S (after applying the KDF function), lt , or the TGIF-TBC round key. We assume a multiplexer costs ~ 2.75 GEs and an XOR gate costs ~ 2.25 GEs. In total, this adds up to ~ 864 GEs on top of TGIF-TBC.

The estimations for the area of TGIF-TBC are provided in Table 5.1.

In order to design a combined encryption/decryption circuit, we show below that the decryption costs only extra 32 multiplexers and ~ 32 OR gates, or ~ 100 GEs.

Hardware Cost of TGIF-N2. TGIF-N2 is similar to TGIF-N1, with an additional mask V . Hence, the additional cost comes from the need to store and process this mask. The storage cost is simply 128 extra Flip-Flops. However, the processing cost can be tricky, especially since we adopt a serial concept for the implementation of ρ . Hence, we also adopt a serial concept for the processing of V . We assume that V will be updated in parallel to ρ and we merge the masking and ρ operations. Consequently, we need 64 XORs for the masking, 3 XORs for doubling, 5 XORs in order to correct the domain separation bits after each block (note that 3 bits are fixed), and 1 Flip-Flop for the serialization of doubling. Overall, we need ~ 800 GEs on top of TGIF-N1, which is again smaller than almost all other AEAD designs (except other TGIF variants), while achieving BBB security.

The arguments about serialization, unrolling and decryption are the same for all TGIF-N variants. Thanks to the shared structure, these arguments also generally apply to TGIF-M.

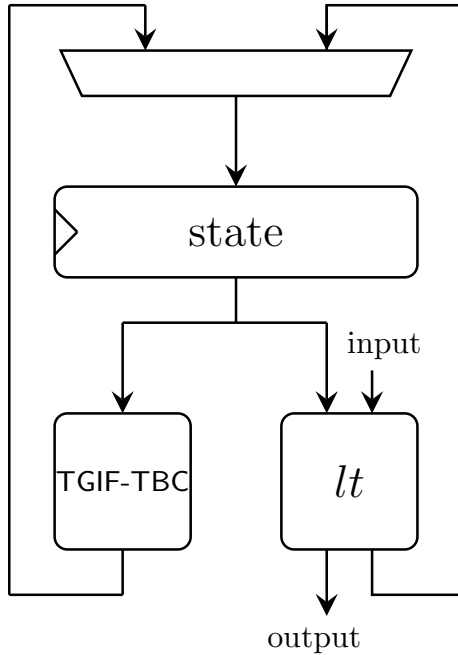

Figure 6.1: Expected architectures for TGIF-TBC and TGIF.

6.2.2 Primitives Choices

LFSR-Based Counters. The NIST call for lightweight AEAD algorithms requires that such algorithms must allow encrypting messages of length at least 2^{50} bytes while still maintaining their security claims. This means that using TBCs whose block sizes are 128 and 64 bits, we need a block counter of a period of at least 2^{46} and 2^{47} , respectively. While this can be achieved by a simple arithmetic counter of 46 bits, arithmetic counters can be costly both in terms of area ($3 \sim 5$ GEs/bit) and performance (due to the long carry chains which limit the frequency of the circuit). In order to avoid this, we decided to use LFSR-based counters, which can be implemented using a handful of XOR gates ($3 \text{ XORs} \approx 6 \sim 9$ GEs). These counters are consecutive doubling of the key L , which is equivalent to a Galois LFSR. This, in addition to the architecture described above, makes the cost of counter almost negligible.

Tag Generation. While TGIF has a lot of similarities compared to iCOFB, the original iCOFB simply outputs the final chaining value as the tag. Considering hardware simplicity, we changed it so that the tag is the final output state (*i.e.*, the same way as the ciphertext blocks). In order to avoid branching when it comes to the output of the circuit, the tag is generated as $G(S)$ instead of S . In hardware, this can be implemented as $\rho(S, 0^n)$, *i.e.*, similar to the encryption of a zero vector. Consequently, the output bus is always connected to the output of ρ and a multiplexer is avoided.

Mask Generation in KDF. Similar to tag generation, we generate the masks by applying G to a standard n -bit keyed permutation. The reason for that is to be able to reuse the same circuit used for the normal operation of TGIF for KDF. Moreover, it allows us to easily output and store the masks during the first pass of TGIF-N, to be used during the second pass. Effectively, KDF2 is equivalent to the algorithm in Figure 6.2, where for KDF1 lines 5 to 7 will be substituted with a line $[V \leftarrow 0^n]$. This algorithm shows that the KDF has the same structure as the main encryption/decryption part of TGIF itself and the same hardware circuit can be very easily reused with almost no overhead.

Algorithm KDF2(N, K)

1. $S \leftarrow 0^n$
 2. $(S, \eta) \leftarrow \rho(S, N)$
 3. $S \leftarrow E_K(S)$
 4. $(S, L) \leftarrow \rho(S, 0^n)$
 5. $S \leftarrow E_{K \oplus 1}(S)$
 6. $(S, V) \leftarrow \rho(S, 0^n)$
 7. $S \leftarrow 0^n$
 8. **return** (L, V)
-

Figure 6.2: Alternative description of KDF2 (KDF for ICE2). KDF1 is obtained by substituting lines 5 to 7 with single line $[V \leftarrow 0^n]$.

Padding. The padding function used in TGIF is chosen so that the padding information is always inserted in the most significant byte of the last block of the message/AD. Hence, it reduces the number of decisions for each byte to only two decisions (either the input byte or a zero byte, except the most significant byte which is either the input byte or the byte length of that block). Besides, it is also the case when the input is treated as a string of words (16-, 32-, 64- or 128-bit words). This is much simpler than the classical 10^* padding approach, where every word has a lot of different possibilities when it comes to the location of the padding string. Besides, usually implementations maintain the length of the message in a local variable/register, which means that the padding information is already available, just a matter of placing it in the right place in the message, as opposed to the decoder required to convert the message length into 10^* padding.

Padding Circuit for Decryption. One of the main features of TGIF is that it is inverse free and both the encryption and decryption algorithms are almost the same. However, it can be tricky to understand the behavior of decryption when the last ciphertext block has length $< n$. In order to understand padding in decryption, we look at the ρ and ρ^{-1} functions when the input plaintext/ciphertext is partial. The ρ function applied on a partial plaintext block is shown in Equation (6.1). If ρ^{-1} is directly applied to $\text{pad}_n(C)$, the corresponding output will be incorrect, due to the truncation of the last ciphertext block. Hence, before applying ρ^{-1} we need to regenerate the truncated bits. It can be verified that $C' = \text{pad}_n(C) \oplus \text{msb}_{n-|C|}(G(S))$. Once C' is regenerated, ρ^{-1} can be computed as shown in Equation (6.2)

$$\begin{bmatrix} S' \\ C' \end{bmatrix} = \begin{bmatrix} 1 & 1 \\ G & 1 \end{bmatrix} \begin{bmatrix} S \\ \text{pad}_n(M) \end{bmatrix} \quad \text{and} \quad C = \text{lsb}_{|M|}(C'). \quad (6.1)$$

$$C' = \text{pad}_n(C) \oplus \text{msb}_{n-|C|}(G(S)) \quad \text{and} \quad \begin{bmatrix} S' \\ M \end{bmatrix} = \begin{bmatrix} 1 \oplus G & 1 \\ G & 1 \end{bmatrix} \begin{bmatrix} S \\ C' \end{bmatrix}. \quad (6.2)$$

While this looks like a special padding function, in practice it is simple. First of all, $G(S)$ needs to be calculated anyway. Besides, the whole operation can be implemented in two steps:

$$\begin{aligned} M &= C \oplus \text{lsb}_{|C|}(G(s)), \\ S' &= \text{pad}_n(M) \oplus S, \end{aligned}$$

which can have a very simple hardware implementation, as discussed in the next paragraph.

Encryption-Decryption Combined Circuit. One of the goals of TGIF is to be efficient for implementations that require a combine encryption-decryption datapath. Hence, we made sure that the algorithm is inverse free, *i.e.*, it does not use the inverse function of TGIF-TBC or $G(S)$. Moreover, ρ and ρ^{-1} can be combined using only one multiplexer, whose size depends on the size of the input/output bus. The same circuit can be used to solve the padding issue in decryption, by padding M instead of C . The tag verification operation simply checks that if $\rho(S, 0^n)$ equals to T , which can be serialized depending on the implementation of ρ .

Choice of the G Matrix. We chose the position of G so that it is applied to the output state. This removes the need of G for AD processing, which improves (e.g.) software performance. In Section 4, we listed the security condition for G , and we choose our matrix G so that it meets these conditions and suits well for various hardware and software.

We noticed that for lightweight applications, most implementations use an input/output bus of width ≤ 32 . Hence, we expect the implementation of ρ to be serialized depending on the bus size. Consequently, the matrix used in iCOFB can be inefficient as it needs a feedback operation over 4 bytes, which requires up to 32 extra Flip-Flops in order to be serialized, something we are trying to avoid in TGIF. Moreover, the serial operation of ρ is different for byte, which requires additional multiplexers.

However, we observed that if the input block is interpreted in a different order, both problems can be avoided. First, it is impossible to satisfy the security requirements of G without any feedback signals, *i.e.*, G is a bit permutation.

- If G is a bit permutation with at least one bit going to itself, then there is at least one non-zero value on the diagonal, so $I + G$ has at least 1 row that is all 0s.
- If G is a bit permutation without any bit going to itself, then every column in $I + G$ has exactly two 1's. The sum of all rows in such matrix is the 0 vector, which means the rows are linearly dependent. Hence, $I + G$ is not invertible.

However, the number of feedback signals can be adjusted to our requirements, starting from only 1 feedback signal. Second, we noticed that the input block/state of length n bits can be treated as several independent sub-blocks of size n/w each. Hence, it is enough to design a matrix G_s of size $w \times w$ bits and apply it independently n/w times to each sub-block. The operation applied on each sub-block in this case is the same, (*i.e.*, as we can distribute the feedback bits evenly across the input block). Unfortunately, the choice of w and G_s that provides the optimal results depends on the implementation architecture. However, we found out that the best trade-off/balance across different architectures is when $w = 8$ and G_s uses a single bit feedback.

In order to verify our observations, we generated a family of matrices with different values of w and G_s , and measured the cost of implementing each of them on different architectures.

Implementations

7.1 Software Performances

7.1.1 Software implementations

The GIFT article presents extremely fast software implementations of the cipher on various recent Intel processors, some as low as 2.57 c/B (actually our case will be even faster as no bitslice packing/unpacking is required in TGIF). However, these bitslice implementations are heavily relying on the parallelism offered by some operating modes. In our case, this parallelism is not present as Remus is not a parallel mode. We do note that the Misty structure in TGIF offers a twofold parallelization though.

In practice several easy solutions are possible to overcome this performance limitation. One solution is to let the two communicating entities to use short sessions, which would re-enable the server side to parallelise the encryption/decryption of the various sessions. Another possible solution to still use these very fast bitslice implementations is to let the server to communicate with several clients in parallel. This is in fact very probably what will happen in practice (a server communicating with many clients is the main reason why fast software implementations are interesting). Even in the case where the arriving data is always from new clients, bitslicing remains possible by bitslicing the key schedule part of TGIF-TBC as well.

7.1.2 Micro-controller implementations

No micro-controller implementation has been reported on GIFT or TGIF yet to the best of our knowledge. However, we believe that TGIF-TBC will be a strong candidate for micro-controllers: its total number of rounds/operations is small compared to most other lightweight ciphers, while the special bitslice representation of 4 rounds of GIFT has been set especially to avoid any packing/unpacking cost and to perform the linear layer efficiently.

7.2 ASIC Performances

We have implemented the round-based architecture of all the variants of TGIF, using a simple lightweight interface. The results show that TGIF is very lightweight, requiring less than 6 KGE to reach around 6 Gbps. Moreover, we estimated that the round based implementation, while not as efficient as the step based implementation, it can be around 700 GEs smaller. The largest and most secure step-based implementation costs between 6 and 7 kGEs.

Table 7.1: ASIC Step-Based Implementations of TGIF using the TSMC 65nm standard cell library at minimum area. Power and Energy are estimated at 10 Mhz. Energy is for 1 TBC call for TGIF-N members and 2 TBC calls for TGIF-M members.

Variant	Cycles	Area w/o interface (kGE)	Area (kGE)	Minimum Delay (ns)	Throughput (Gbps)	Power (μ W)	Energy (pJ)	Thput/Area (Gbps/kGE)	NR Security	NM Security
TGIF-N1	22	4307	4813	1.58	3.68	433.1	952.6	0.76	64	-
TGIF-N2	22	5406	5950	1.58	3.68	430	946	0.62	128	-
TGIF-M1	22(AD)/44(M)	4250	4940	1.58	2.45	467.7	2057	0.5	64	64
TGIF-M2	22(AD)/44(M)	5569	6236	1.58	2.45	528.2	2324	0.39	128	64~128

Table 7.2: ASIC Step-Based Implementations of TGIF using the TSMC 65nm standard cell library at 1GHz

Variant	Cycles	Area (kGE)	Minimum Delay (ns)	Throughput (Gbps)	Thput/Area (Gbps/kGE)	NR Security	NM Security
TGIF-N1	22	5945	1	5.9	1	64	-
TGIF-N2	22	7009	1	5.9	0.85	128	-
TGIF-M1	22(AD)/44(M)	6133	1	3.87	0.63	64	64
TGIF-M2	22(AD)/44(M)	7345	1	3.87	0.52	128	64~128

Acknowledgments

The second and fourth authors are supported by the Temasek Labs grant (DSOCL16194).

Bibliography

- [1] Banik, S., Bogdanov, A., Luykx, A., Tischhauser, E.: SUNDABE: Small Universal Deterministic Authenticated Encryption for the Internet of Things. *IACR Trans. Symmetric Cryptol.* **2018**(3) (2018) 1–35
- [2] Banik, S., Pandey, S.K., Peyrin, T., Sasaki, Y., Sim, S.M., Todo, Y.: GIFT: A small present - towards reaching the limit of lightweight encryption. In: *CHES*. Volume 10529 of *Lecture Notes in Computer Science.*, Springer (2017) 321–345
- [3] Bellare, M., Namprempre, C.: Authenticated encryption: Relations among notions and analysis of the generic composition paradigm. *J. Cryptology* **21**(4) (2008) 469–491
- [4] Bellare, M., Rogaway, P., Wagner, D.A.: The EAX mode of operation. In: *FSE*. Volume 3017 of *Lecture Notes in Computer Science.*, Springer (2004) 389–407
- [5] Bertoni, G., Daemen, J., Peeters, M., Assche, G.V.: Duplexing the Sponge: Single-Pass Authenticated Encryption and Other Applications. In: *Selected Areas in Cryptography*. Volume 7118 of *Lecture Notes in Computer Science.*, Springer (2011) 320–337
- [6] Biham, E., Biryukov, A., Shamir, A.: Cryptanalysis of skipjack reduced to 31 rounds using impossible differentials. In: *Advances in Cryptology - EUROCRYPT '99*, International Conference on the Theory and Application of Cryptographic Techniques, Prague, Czech Republic, May 2-6, 1999, Proceeding. (1999) 12–23
- [7] Biham, E., Shamir, A.: Differential cryptanalysis of DES-like cryptosystems. In: *Advances in Cryptology - CRYPTO '90*, 10th Annual International Cryptology Conference, Santa Barbara, California, USA, August 11-15, 1990, Proceedings. (1990) 2–21
- [8] Bogdanov, A., Wang, M.: Zero correlation linear cryptanalysis with reduced data complexity. In: *Fast Software Encryption - 19th International Workshop, FSE 2012*, Washington, DC, USA, March 19-21, 2012. Revised Selected Papers. (2012) 29–48
- [9] Chakraborti, A., Datta, N., Nandi, M., Yasuda, K.: Beetle family of lightweight and secure authenticated encryption ciphers. *IACR Transactions on Cryptographic Hardware and Embedded Systems* (2018) 218–241
- [10] Chakraborti, A., Iwata, T., Minematsu, K., Nandi, M.: Blockcipher-based authenticated encryption: How small can we go? In: *CHES*. Volume 10529 of *Lecture Notes in Computer Science.*, Springer (2017) 277–298
- [11] Chakraborti, A., Iwata, T., Minematsu, K., Nandi, M.: Blockcipher-based authenticated encryption: How small can we go? In: *International Conference on Cryptographic Hardware and Embedded Systems*, Springer (2017) 277–298
- [12] Chakraborti, A., Iwata, T., Minematsu, K., Nandi, M.: Blockcipher-based authenticated encryption: How small can we go? (full version of [10]). *IACR Cryptology ePrint Archive* **2017** (2017) 649

- [13] Chang, D., Dworkin, M., Hong, S., Kelsey, J., Nandi, M.: A Keyed Sponge Construction with Pseudo-randomness in the Standard Model. NIST SHA-3 2012 Workshop (2012)
- [14] Daemen, J., Rijmen, V.: The Design of Rijndael: AES - The Advanced Encryption Standard. Information Security and Cryptography. Springer (2002)
- [15] Dobraunig, C., Eichlseder, M., Mendel, F., Schl affer, M.: Ascon v1. 2. Submission to the CAESAR Competition (2016)
- [16] George Mason University: ATHENa: Automated Tools for Hardware EvaluationN. <https://cryptography.gmu.edu/athena/> (2017)
- [17] Handschuh, H., Preneel, B.: Key-Recovery Attacks on Universal Hash Function Based MAC Algorithms. In Wagner, D., ed.: Advances in Cryptology - CRYPTO 2008. Volume 5157 of LNCS., Springer (2008) 144–161
- [18] Iwata, T., Khairallah, M., Minematsu, K., Peyrin, T.: Remus v1. Submission to NIST Lightweight Cryptography Project (2019)
- [19] Iwata, T., Khairallah, M., Minematsu, K., Peyrin, T.: Romulus v1. Submission to NIST Lightweight Cryptography Project (2019)
- [20] Iwata, T., Minematsu, K., Peyrin, T., Seurin, Y.: Zmac: a fast tweakable block cipher mode for highly secure message authentication. In: Annual International Cryptology Conference, Springer (2017) 34–65
- [21] Jha, A., List, E., Minematsu, K., Mishra, S., Nandi, M.: XHX - A framework for optimally secure tweakable block ciphers from classical block ciphers and universal hashing. LATINCRYPT 2017 (2017) available at <https://eprint.iacr.org/2017/1075>.
- [22] Joux, A.: Authentication Failures in NIST Version of GCM. Comments submitted to NIST Modes of Operation Process (2006) Available at http://csrc.nist.gov/groups/ST/toolkit/BCM/documents/comments/800-38_Series-Drafts/GCM/Joux_comments.pdf.
- [23] Khairallah, M., Chattopadhyay, A., Peyrin, T.: Looting the luts: Fpga optimization of aes and aes-like ciphers for authenticated encryption. In: International Conference in Cryptology in India, Springer (2017) 282–301
- [24] Knudsen, L.: Deal-a 128-bit block cipher. complexity **258**(2) (1998) 216
- [25] Krovetz, T., Rogaway, P.: The software performance of authenticated-encryption modes. In: FSE. Volume 6733 of Lecture Notes in Computer Science., Springer (2011) 306–327
- [26] Krovetz, T., Rogaway, P.: The software performance of authenticated-encryption modes. In: International Workshop on Fast Software Encryption, Springer (2011) 306–327
- [27] Kumar, S., Haj-Yihia, J., Khairallah, M., Chattopadhyay, A.: A comprehensive performance analysis of hardware implementations of caesar candidates. IACR Cryptology ePrint Archive **2017** (2017) 1261
- [28] Matsui, M.: Linear cryptanalysis method for DES cipher. In: Advances in Cryptology - EUROCRYPT '93, Workshop on the Theory and Application of Cryptographic Techniques, Lofthus, Norway, May 23-27, 1993, Proceedings. (1993) 386–397
- [29] Matsui, M.: New Block Encryption Algorithm MISTY. In Biham, E., ed.: Fast Software Encryption, 4th International Workshop, FSE '97, Haifa, Israel, January 20-22, 1997, Proceedings. Volume 1267 of Lecture Notes in Computer Science., Springer (1997) 54–68
- [30] Medwed, M., Standaert, F.X., Gro sch adl, J., Regazzoni, F.: Fresh re-keying: Security against side-channel and fault attacks for low-cost devices. In: International Conference on Cryptology in Africa, Springer (2010) 279–296

- [31] Mennink, B.: Optimally secure tweakable blockciphers. In: FSE. Volume 9054 of Lecture Notes in Computer Science., Springer (2015) 428–448
- [32] Mennink, B., Reyhanitabar, R., Vizár, D.: Security of Full-State Keyed Sponge and Duplex: Applications to Authenticated Encryption. In: ASIACRYPT (2). Volume 9453 of Lecture Notes in Computer Science., Springer (2015) 465–489
- [33] Messerges, T.S.: Securing the aes finalists against power analysis attacks. In: International Workshop on Fast Software Encryption, Springer (2000) 150–164
- [34] Mouha, N., Mennink, B., Herrewewege, A.V., Watanabe, D., Preneel, B., Verbauwhede, I.: Chaskey: An Efficient MAC Algorithm for 32-bit Microcontrollers. In: Selected Areas in Cryptography. Volume 8781 of Lecture Notes in Computer Science., Springer (2014) 306–323
- [35] Peyrin, T., Seurin, Y.: Counter-in-tweak: Authenticated encryption modes for tweakable block ciphers. In: CRYPTO (1). Volume 9814 of Lecture Notes in Computer Science., Springer (2016) 33–63
- [36] Peyrin, T., Seurin, Y.: Counter-in-tweak: authenticated encryption modes for tweakable block ciphers. In: Annual International Cryptology Conference, Springer (2016) 33–63
- [37] Rogaway, P.: Efficient instantiations of tweakable blockciphers and refinements to modes OCB and PMAC. In: ASIACRYPT. Volume 3329 of Lecture Notes in Computer Science., Springer (2004) 16–31
- [38] Rogaway, P.: Nonce-based symmetric encryption. In: FSE. Volume 3017 of Lecture Notes in Computer Science., Springer (2004) 348–359
- [39] Rogaway, P., Shrimpton, T.: A provable-security treatment of the key-wrap problem. In: EUROCRYPT. Volume 4004 of Lecture Notes in Computer Science., Springer (2006) 373–390
- [40] Sun, L., Wang, W., Wang, M.: More accurate differential properties of led64 and midori64. IACR Transactions on Symmetric Cryptology **2018**(3) (Sep. 2018) 93–123
- [41] Todo, Y.: Structural evaluation by generalized integral property. In: Advances in Cryptology - EUROCRYPT 2015 - 34th Annual International Conference on the Theory and Applications of Cryptographic Techniques, Sofia, Bulgaria, April 26-30, 2015, Proceedings, Part I. (2015) 287–314
- [42] Todo, Y., Morii, M.: Bit-based division property and application to SIMON family. In: Fast Software Encryption - 23rd International Conference, FSE 2016, Bochum, Germany, March 20-23, 2016, Revised Selected Papers. (2016) 357–377
- [43] Wang, L., Guo, J., Zhang, G., Zhao, J., Gu, D.: How to build fully secure tweakable blockciphers from classical blockciphers. In: ASIACRYPT (1). Volume 10031 of Lecture Notes in Computer Science. (2016) 455–483
- [44] Xiang, Z., Zhang, W., Bao, Z., Lin, D.: Applying MILP method to searching integral distinguishers based on division property for 6 lightweight block ciphers. In: Advances in Cryptology - ASIACRYPT 2016 - 22nd International Conference on the Theory and Application of Cryptology and Information Security, Hanoi, Vietnam, December 4-8, 2016, Proceedings, Part I. (2016) 648–678

Appendix

8.1 Domain Separation

Table 8.1: Domain separation byte B of TGIF. Bit b_6 is to be set to the appropriate value according to the parameter sets.

	b_7	b_6	b_5	b_4	b_3	b_2	b_1	b_0	$\text{int}(B)$	case
TGIF-N	0	-	0	0	0	1	0	0	4	A main
	0	-	0	0	1	1	0	0	12	A last unpadded
	0	-	0	0	1	1	0	1	13	A last padded
	0	-	0	0	0	0	1	0	2	M main
	0	-	0	0	1	0	1	0	10	M last unpadded
	0	-	0	0	1	0	1	1	11	M last padded
TGIF-M	0	-	1	0	0	1	0	0	36	A main
	0	-	1	0	1	1	0	0	44	A last unpadded
	0	-	1	0	1	1	0	1	45	A last padded
	0	-	1	0	0	1	1	0	38	M auth main
	0	-	1	0	1	1	1	0	46	M auth last unpadded
	0	-	1	0	1	1	1	1	47	M auth last padded
	0	-	1	0	0	0	1	0	34	M enc main

Changelog

- 29-03-2019: version v1.0